

INSTRUCTION MANUAL

STEADYWEB™

AUTOMATIC TENSION CONTROLLER



5 YEAR WARRANTY



Rochester, NH 03867-4630 U.S.A.

For assistance, please call:

TECHNICAL SERVICE - Installations, Start-Up, Troubleshooting, Repairs, Field Service, Returns: call 603-332-6150 and ask for Technical Support or email to us at [**techsupport@dfc.com**](mailto:techsupport@dfc.com)

CUSTOMER SERVICE - Replacement Parts, Individual Products, Questions about Orders, Manuals: call 603-332-6150 and ask for Customer Service or email to us at [**customerservice@dfc.com**](mailto:customerservice@dfc.com)

SALES - Product Information, Systems Application Questions, and placing orders for standard products and special systems. Please call 603-332-6150 and ask for Sales or email to us at [**sales@dfc.com**](mailto:sales@dfc.com)

Telephone: (603) 332-6150 Fax: (603) 332-3758

E-mail: info@dfc.com Internet: www.dfc.com

READ THIS!

Your SteadyWeb™ Controller has been properly configured at our factory. To install it and start it up, it should only be necessary to use these sections of this manual:

Section 2 - Installation

Section 4 - Calibration the Tension Meter

Section 7 - Tuning for Running Stability

The other sections are for reference and for instruction if you wish to change the configuration at some later time.

TABLE OF CONTENTS

SECTION ONE	DESCRIPTION	PAGE
1.0	General Description	1
1.1	Output Modules, Version of Controller	1
	Pneumatic Output Module (12P)	1
	High Voltage Output Module (12V)	1
	0-10 Volt Compensated Output Module (12D)	1
1.2	SteadyWeb Controller Exploded View	2
1.3	Specifications	3
1.4	Standard Features	
	0-10 Volt Tension Output	4
	4-20mA Tension Output	4
	Automatic Control Mode	4
	Control Voltage Selection	4
	Emergency Stop	4
	Manual Control Mode	4
	Meter Correlation Adjustment	4
	Meter Damping	4
	Output Direction Selection (normal/reverse)	4
	Output Meter	4
	Power Voltage Selection	4
	Ratio	5
	Remote Tension On/Off	5
	Remote Tension Set	5
	Sample & Hold	5
	Soft Start	5
	Speed Follow	5
	Speed Match	5
	Status Lights	5
	Tension Display	5
	Transducer Voltage Selection	5
1.5	Options	
	220 Volt Power	6
	24 Volt Output	6
	45 Volt Output	6
	Chassis Configuration (CC)	6
	DC Tahometer Card	6
	Digital Meter	6
	Dual Calibration	6
	Dual Transducer Input	6
	Extended Range	6
	Metric Air Tubing	6
	Nonstandard Meter Scale	6
	Pulse Tachometer Card	6
	Remote Operator Devices (H6)	7
	Remote Pneumatic Module	7
	Remote Tension Amplifier	7
	Reverse Output	7
	Taper Adjustment on Front Panel	7
	Taper Tension	7
	Tension Limit Switch	7
1.6	Front Panel & Operator Devices	8

SECTION TWO	INSTALLATION OF STANDARD UNIT	
2.0	Dimensions	9
2.1	Installing the Enclosure	10
2.2	Electrical Connections	11
2.3	Electrical Connections for Options	12
SECTION THREE	INSTALLATION OF H6 AND CC CONFIGURATIONS	
3.0	H6 Configuration	13
	Dimensions	14
3.1	CC Configuration	15
	Dimensions	15
	Electrical Connections	16
SECTION FOUR	CALIBRATING THE TENSION METER	
4.0	Mechanical Zero	18
4.1	Calibration	18
SECTION FIVE	SET-UP AND ADJUSTMENTS OF STANDARD UNIT	
5.0	Tension Zones	20
5.1	The Control Board	21
5.2	The Power Board	22
5.3	Power Voltage Selection	23
5.4	Control Voltage Selection	23
5.5	4-20mA or 0-20mA Output	24
5.6	Emergency Stop	25
5.7	High Voltage Output Module (12V only)	26
5.8	Meter Correlation	27
5.9	Meter Damping	27
5.10	Output Direction	27
5.11	Output Meter	28
5.12	Pneumatic Output Module (12P only)	28
5.13	Ratio Up/Down	29
5.14	Remote Tension Amplifier Installed?	30
5.15	Remote Tension On/Off	30
5.16	Remote Tension Set	30
5.17	Sample and Hold	31
5.18	Soft Start	31
5.19	Speed Follow	33
5.20	Tachometer Card Installed?	34
5.21	TLS Card Installed?	34
5.22	Transducer Voltage Selection	34
SECTION SIX	SET-UP AND ADJUSTMENTS OF OPTIONS	
6.0	220 Volt Power Input	36
6.1	24 Volt Output	36
6.2	45 Volt Output	36
6.3	DC Tachometer Card	36
6.4	Digital Meter	38
6.5	Dual Calibration	40
6.6	Dual Transducer Input	40
6.7	Extended Range	40
6.8	Pulse Tachometer Card	40
6.9	Remote Tension Amplifier	42
6.10	Taper Adjustment of Front Panel	43

6.11	Taper Tension	43
	Taper by Diameter Computer	43
	Taper by Rider Roll or Voltage Source	44
6.12	Tension Limit Switch (TLS)	46
SECTION SEVEN	TUNING FOR RUNNING STABILITY	
7.0	Introduction	49
7.1	Description of Adjustments	49
7.2	Tuning Procedure	50
7.3	Tuning the Speed Follow Function	50
SECTION EIGHT	REPLACEMENT PARTS	
8.0	Standard Circuit Boards	52
8.1	Optional Circuit Boards	52
8.2	Operator Devices	52
8.3	Output Modules	52
8.4	Fuses	52
8.5	Ribbon Cables	52
8.6	Relays	53
8.7	Miscellaneous	53

APPENDICES

A	Locations of Standard Adjustments	54
B	DIP Switch Settings	55
C	Basic Set-up	58
D	Electrical Connections of Standard SteadyWeb	60
E	Electrical Connections of Options	61
F	Transducer Electrical Connections	62
G	Typical Tensions	66
H	Front Board	67
I	Troubleshooting	68
	TERMS AND CONDITIONS OF SALE	69
	INDEX	70,71

LIST OF ILLUSTRATIONS

<u>FIGURE</u>	<u>DESCRIPTION</u>	<u>PAGE</u>
1	SteadyWeb Controller - Exploded View	2
2	Front Panel and Operator Devices	8
3	Dimensions	9
4	Mounting Screw Locations	10
5	Cover Removal	10
6	Electrical Connections	11
7	Electrical Connections of Options	12
8	Remote Operator Device Configuration	13
9	Dimensions of H6	14
10	Chassis Configuration (CC)	15
11	Dimensions of CC Configuration	15
12	Electrical Connections of CC	16,17
13	Meter Access Holes	18
14	Web Path for Meter Calibration	19
15	Tension Zones	20
16	Control Board	21
17	Power Board	22
18	Power Switch	23
19	E-Stop Electrical Connections	25
20	V-OUT Module	26
21	Ratio Contact Electrical Connections	29
22	Remote Tension On/Off Button Connections	30
23	Sample & Hold Contact	31
24	Soft Start Connections	32
25	Transducer Voltage Switch	35
26	DC Tach Option Card	36
27	DC Tachometer Connections	37
28	Digital Meter Display	39
29	Digital Meter Card	39
30	Pulse Tach Option Card	41
31	Pulse tachometer Connections	41
32	Remote Tension Amplifier Electrical Connections	43
33	Taper Dia/Calc Option Card	43
34	Taper RIDER Option Card	45
35	Rider Pot. Connections	45
36	10 Volt Source Connections	45
37	TLS Option Card	46
38	TLS Reset Button Connections	47
39	TLS Relay Connections	48
40	Tuning Pots.	49
41	Standard Adjustments - Control Board	54
42	Standard Adjustments - Power Board	54
43	Standard Electrical Connections	60
44	Optional Electrical Connections	61
45	Model C, UPB Transducer Wiring	62
46	RF Transducer Wiring	63
47	TR, NW Transducer Wiring	64
48	LT Transducer Wiring	65
49	Front Board	67

1.0 GENERAL DESCRIPTION

The SteadyWeb tension controller automatically maintains tension of any continuous material at the value selected by the machine operator. It consists of three basic functions:

The first function is performed by the tension amplifier. It supports all of Dover Flexo Electronics tension transducers. (The transducers measure the actual tension in the web). It includes a regulated power supply to excite the transducers, an amplifier to boost the transducer output signal, and a calibration circuit to adjust the tension readout to display actual tension.

The second function is the tension regulator. It compares the output signal from the transducers with the signal from the AUTO Set potentiometer on the front of the SteadyWeb enclosure. If there is a difference, the regulator will either increase or decrease tension to equalize them. The tension amplifier and the tension regulator are both located on the Control board. (See Figure 1)

The third function is performed by the output module. It accepts the output from the tension regulator and actuates a brake, clutch, or variable speed drive system which actually creates the tension in the web.

1.1 OUTPUT MODULES, VERSION OF CONTROLLER

Three output modules are available for the SteadyWeb controller.

- A) Pneumatic output module. This is used to actuate any air operated brake or clutch. It includes a servo valve, a pressure regulator, and an air filter. These items are fitted together into a compact assembly which is normally installed inside the controller enclosure or optionally located remotely. The output range is .5 to 75 psi. SteadyWeb controllers having this module are designated "Version 12P".
- B) High Voltage output module. This module uses SCR's to produce a variable voltage of up to 90 volts DC to operate any electric brake or clutch, including eddy current clutches. 45 volt and 24 volt outputs are optional. This module is also known as the VOUT Card. SteadyWeb controllers having this output module are designated "Version 12V".
- C) 0 to 10 Volt DC compensated output module. This module is in the form of a 16 pin DIP Integrated Circuit that plugs into the Power board near the top center. It is designated U203. See Figure 17. This output is used to control DC drives or other variable speed drive systems, usually in intermediate tension zones. This output is isolated from ground to make it compatible with all drives. SteadyWeb controllers having this output are designated "Version 12D".

All SteadyWeb controllers may be easily converted from one output to another if desired. There are five locations for plug-in cards for optional features, three on the Control board and two on the Power board. See Figures 16, 17.

1.2 STEADYWEB CONTROLLER EXPLODED VIEW

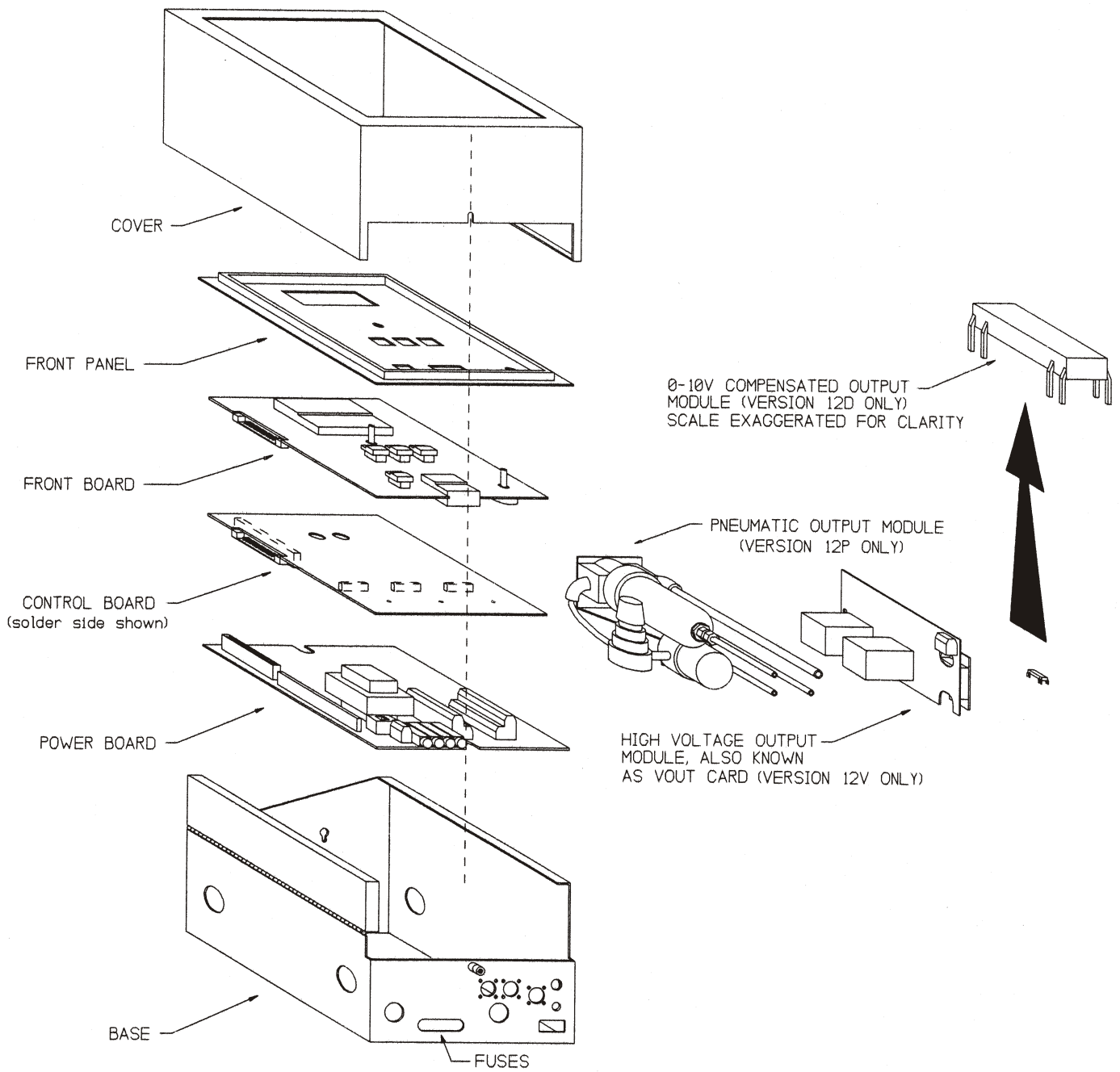

Figure 1 - STEADYWEB CONTROLLER - EXPLODED VIEW

1.3 SPECIFICATIONS

POWER INPUT	12P and 12D	120/240 Volts 60/50Hz single phase @ 1 Amp
	12V	120/240 Volts 60/50Hz single phase @ 5 Amp
OUTPUT	12P	0.5 to 75 psi (.03 to 5,17 bar)
	12V	90 Volts DC, 45 VDC, 24 VDC, all @ 4 Amp
	180VDC @4 Amp and 230VAC Input
	12D	0-10 Volts DC, compensated and isolated
TENSION SIGNAL OUTPUT		0-10 Volts DC
	4-20 MA into 500 ohm maximum load
ENCLOSURE		Steel, powder resin painted, NEMA 1
WEIGHT		26 lbs. (11,8 KG)
AIR CONNECTIONS:12P In		3/8 inch plastic tubing (5/16", 8mm optional)
	Out	1/4 inch plastic tubing (6mm)
INTERNAL AIR FILTER 12P		5 micron, 1/2 pint bowl, automatic drain
TRANSDUCER SIGNAL		500 mv DC per pair at rated load, 1.0 Volt with
	Extended Range option
MATING TRANSDUCER CABLE CONNECTORS		Amphenol MS3106A-10SL-3S
ZERO (TARE) RANGE		95% of transducer rating, minimum
CALIBRATION RANGE		25:1
TEMPERATURE RANGE		32 to 104 deg.F (0-40 deg.C)
SYSTEM ACCURACY		1 - 3% typical
TENSION METER		Analog, 2%, 1ma, 48 ohm
OUTPUT RANGE		0-100% Max., Min. = 0-20% of Max.
MANUAL MODE OUTPUT RANGE		0-100%
OUTPUT RATIO RANGES		1:10(multiplier) and 10:1(divider)
STANDARD TENSION METER SCALES		0 - 1,5,10,25,50,100,150,250,500,1000
TENSION LIMIT SWITCH RELAY CONTACTS (option)		SPDT rated @ 10A/30VDC, 10A/250VAC
TAPER TENSION RANGE (option)		0-100%
TAPER TENSION INPUTS (option)		
Code TTDCT (using DC Tachs) . . .		Switch selected, 3V to 250V
Code TTPT (using Pulse Tachs) . . .		300Hz to 40KHz at max. line speed
Code TTF (Roll Follower)		10K ohm pot. minimum
Code TTR (external voltage)		0-10VDC core to full roll

1.4 STANDARD FEATURES

SOME OF THESE FUNCTIONS REQUIRE CONFIGURING OR EXTERNAL WIRING. REFER TO SECTION 5 FOR CONFIGURING AND SECTION 2.2 FOR WIRING.

- 0-10 VOLT DC TENSION OUT. Proportional to web tension. Used as an input to other control systems, computers or data collection devices.
- 4-20mA TENSION OUT. Proportional to web tension. Used as an input to other control systems, computers or data collection devices.
- AUTOMATIC CONTROL MODE. The controller output is determined by the difference between web tension and the AUTO tension set knob position. The internal regulator automatically varies the output as required to maintain set tension.
- CONTROL VOLTAGE SELECTION. Choose one of three available Control board outputs. They are 0 to +10 VDC, 0 to -10VDC, and -10 to +10VDC. The 0 to +10VDC output operates pneumatic (12P) and high voltage (12V) output modules when used. Any of the three outputs can be used in the 12D version of the SteadyWeb.
- EMERGENCY STOP. Controller immediately goes to full output or zero output (selectable) upon closure of an external contact. Normally full output is used on unwinds to stop the roll of material quickly. Zero output is used for rewind or intermediate controllers.
- MANUAL CONTROL MODE. The controller output is determined only by the position of the MANUAL set knob. No change occurs unless the knob is turned. Used during machine set-up or during trouble-shooting.
- METER CORRELATION ADJUSTMENT. This causes the position of the AUTO set pot. to correspond to the position of the needle on the analog tension meter. For example; if the AUTO pot. is set at 4 on its dial, the tension meter would read 40% of full scale. This is important for the proper operation of the controller.
- METER DAMPING. Eliminates vibration of the analog tension meter needle. Also minimizes flicker of the optional digital meter.
- OUTPUT DIRECTION. Select between Normal and Reverse output. Most applications use the Normal selection, controller output goes up when tension falls below the set level. The Reverse selection causes output to go down when tension falls below the set level. It is used in intermediate tension zones where the transducers are located after the nip rolls they control, and for driven unwinds.
- OUTPUT METER. Displays the controller output, measured in 0 to 100 percent. Set 0 at left end of scale for Version 12P, 12V and some 12D controllers. Or Set 0 at center of scale when using an optional center-zero meter for Version 12D controllers having -10 to +10 volt outputs.
- POWER VOLTAGE SELECTION. The SteadyWeb controller is designed to operate on two ranges of AC power; 110-120 Volts 60/50 Hz, and 220-240 Volts 60/50 Hz. A slide switch on the Power board selects between the two.

- **RATIO.** Takes the sampled output and multiplies it (unwind applications) or divides it (rewind applications) by a factor adjustable between 1 and 10. Used in flying splice applications to help provide a match between controller output and roll diameter.
- **REMOTE TENSION ON/OFF.** Requires two momentary pushbuttons supplied by customer and located external to the controller. Enables the machine operator to turn the controller output on and off at the remote location and at the controller.
- **REMOTE TENSION SET.** Locate an AUTO Tension Set potentiometer external to the controller in addition to the one on the front panel of the controller. Select between the two with a switch inside the controller. Only one pot. can be active at any one time.
- **SAMPLE AND HOLD.** Locks the controller output at whatever level it may be when an external contact closes, and maintains it there until the contact opens. Usually used in flying splice applications to prevent instability during the splice. Also actuated by the RATIO function.
- **SOFT START.** Used on unwinds. Actuated either automatically upon a loss of tension below the preset trip point (after an adjustable delay), immediately upon an external contact closure, or by machine speed. Controller output is reduced to a preset low level to prevent brake lock-up when the machine starts. When tension rises above the trip point, the controller goes back to the automatic control mode. Does not operate in the MANUAL control mode. Actuation by machine speed requires an optional Tachometer Card (see Options, Section 1.5)
- **SPEED FOLLOW.** This is a special function normally used on Version 12D SteadyWebs controlling tension in an intermediate zone (see Tension Zone drawing, Section 5.0, page 20) or surface driven rewinds and unwinds. Versions 12P and 12V can also use it if they are controlling a clutch which has a constant input speed. In any case, the controller must be equipped with an optional DC Tach card or Pulse Tach card.

The Control board contains a regulator circuit, separate from the tension regulator, that accepts a line speed signal and, optionally, a nip roll speed signal. The line speed signal causes the output of the controller to follow (go up and down with) line speed. The output of the tension regulator then trims the follower output as needed to maintain set tension.

The follower method described above is recommended over the Speed Match method for most applications because it is less affected by tachometer drift, is easier to set up and its adjustment is less critical, and will not result in a run-away condition if the nip roll speed signal is lost.

- **SPEED MATCH.** The same as Speed Follow above, except that the nip roll speed input is also used. In this case, the nip roll is speed-regulated and the tension regulator trims the roll speed.
- **STATUS LIGHTS.** Show that particular functions are active when lights are illuminated.
- **TENSION DISPLAY.** Web tension is displayed on an analog meter which is calibrated to read out total tension in pounds, newtons, kilograms, or any other desired units. A digital meter is optional.
- **TRANSDUCER VOLTAGE SELECTION.** Choose between 5VDC and 10VDC excitation for the tension transducers. 5VDC is standard. 10VDC is used only for the extended range option.

1.5 OPTIONS (The option code is shown in parentheses)

SOME OF THESE OPTIONAL FUNCTIONS REQUIRE CONFIGURING OR EXTERNAL WIRING. REFER TO SECTION 6 FOR CONFIGURING AND SECTION 2.3 FOR WIRING.

- 220 VOLT POWER (220V). 220 volt 50/60 Hz power input.
- 24 VOLT OUTPUT (24V). For Version 12V only. Factory-installed option with 220V power.
- 45 VOLT OUTPUT (45V). For Version 12V only.
- CHASSIS CONFIGURATION (CC). No cover or front panel on enclosure. Customer supplies all operator devices. Controller must be installed inside customer's enclosure.
- DC TACHOMETER CARD (DCT). Takes the voltage output from one or two DC tachometers and scales it to 0-10 volts DC. This card is required for the Taper Tension (TTDCT) option, the version of Soft Start which is actuated by machine speed, and the Speed Follow function. This card plugs into the Power Board.
- DIGITAL METER (DM). 4 full digits, red 1" high LED's with over and under range indicators. The maximum range is 0000 to 9999. An over-range indicator lights at values over 9999, and an under-range indicator lights at values below 0. Can be read from further away than the analog meter. Up to 2 decimal places.
- DUAL CALIBRATION (DC). Two meter scales for the standard analog tension meter and/or two running-stability setups. The meter scales may have any ratio, limited only by the range of the transducers. Used in those cases in which a wide range of materials having very wide tension requirements are being run.
- DUAL TRANSDUCER INPUT (DTI). Controller receives two separate tension signals, one from each of two sets of transducers. Used when a very wide range of tensions must be controlled. A switch on the front panel selects the tension signal to use. The option card plugs into the left-hand option socket on the Power board. There are no adjustments on this card. The Dual Calibration option (DC) is required.
- EXTENDED RANGE (XR). The transducers are excited by 10 volts instead of the standard 5 volts. Used for low tension applications. The transducers must also have the XR option.
- METRIC AIR TUBING (8MM). For Version 12P only. Air fitting for use of 8mm diameter air supply tubing in place of the standard 3/8 inch tubing.
- NONSTANDARD METER SCALE (NMS). Any nonstandard analog meter scale. Either single or dual scale. See Specifications, page 3, for standard scales.
- PULSE TACHOMETER CARD (PT). Takes the pulse output from one or two rotary encoders, AC tachometers or other types of pulse generators and converts and scales it to 0-10 volts DC. This card is required for the Taper Tension (TTPT) option, the version of Soft Start which is actuated by machine speed, and the Speed Follow function. This card plugs into the Power Board.

- REMOTE OPERATOR DEVICES (H6). No cover on enclosure. Front panel attached to controller via a 6'(length optional) cable. Allows front panel to be installed in customer's control panel and controller to be installed inside.
- REMOTE PNEUMATIC MODULE (2E). For Version 12P only. Allows servo valve to be installed close to the brake/clutch while the controller is located elsewhere.
- REMOTE TENSION AMPLIFIER (RTA). The internal tension amplifier is bypassed and the tension signal is provided by an external remote device such as the TI7. This allows use of special indicator functions, such as intrinsic safety, which are not available in the SteadyWeb controller.
- REVERSE OUTPUT (RO). Controller output goes up when tension exceeds the set point. This is the reverse of normal, when output goes down upon excess tension. Used in intermediate tension zones where the transducers are located after the nip rolls they control. **NOTE:** No additional wiring connections or components are needed to use the Reverse Output feature. It is selected by a switch on the Control board. See section 5.10 for setup.
- TAPER ADJUSTMENT ON FRONT PANEL (XTA). Instead of inside controller.
- TAPER TENSION. For rewind applications. Causes tension to decrease as roll diameter increases. Helps produce a better quality roll by eliminating telescoping, crushed cores, too tight or too loose rolls. Two methods are available, diameter computer and rider roll. The diameter computer method requires machine speed and roll speed signals from the optional DC Tachometer Card or the Pulse Tachometer Card. The rider roll method requires a follower roll in contact with the rewinding roll, or some other roll-sensing device such as a sonic rangefinder to detect the roll diameter. The device must have a 0-10 Volt DC output. Taper is adjustable from 0 to 100%. The taper circuitry is located on a card which is plugged into the Control Board. Here is a list of the different types of taper circuits available:
 - (TTDCT) DC Tachometers used for speed signals.
 - (TTPT) Pulse Tach generators used for speed signals.
 - (TTF) Roll Follower or external 0-10VDC source used.
- TENSION LIMIT SWITCH (TLS). Provides relay contact closure at preset tension levels, either high or low. Usually used as a web break detector. The electronic circuitry is located on a card which is plugged into the Control Board. The relay is located on the Power Board.

1.6 FRONT PANEL AND OPERATOR DEVICES

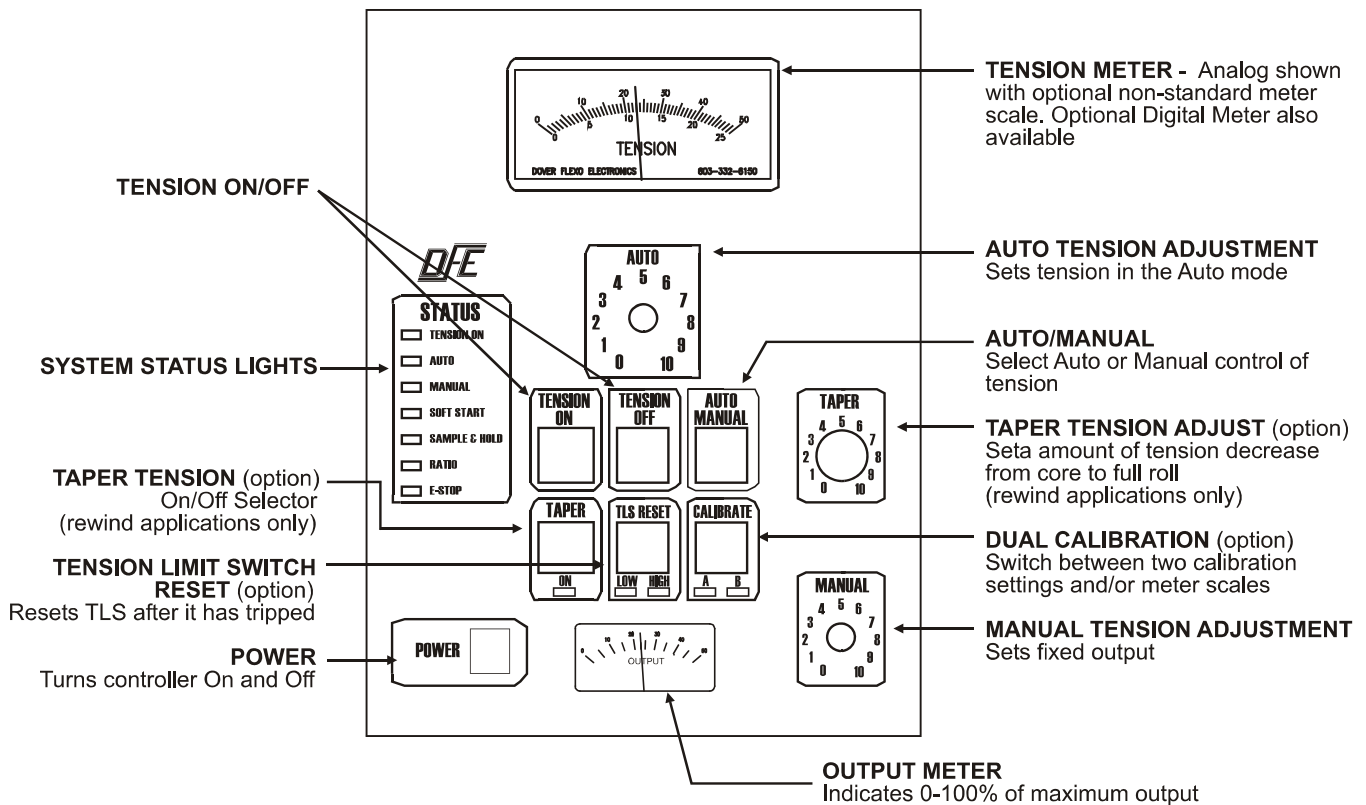

Figure 2 - FRONT PANEL and OPERATOR DEVICES

SECTION 2

INSTALLATION

2.0 DIMENSIONS

	A	B	C	D	E	F	G	H	J	K	L
inch	12.44	10.42	7.75	1.42	2.41	.24	11.78	9.41	10.54	4.71	.42
mm	316	265	197	36	61	6	299	239	268	120	11

Note: Allow 5" (127mm) clearance on the left side for the controller to open completely.

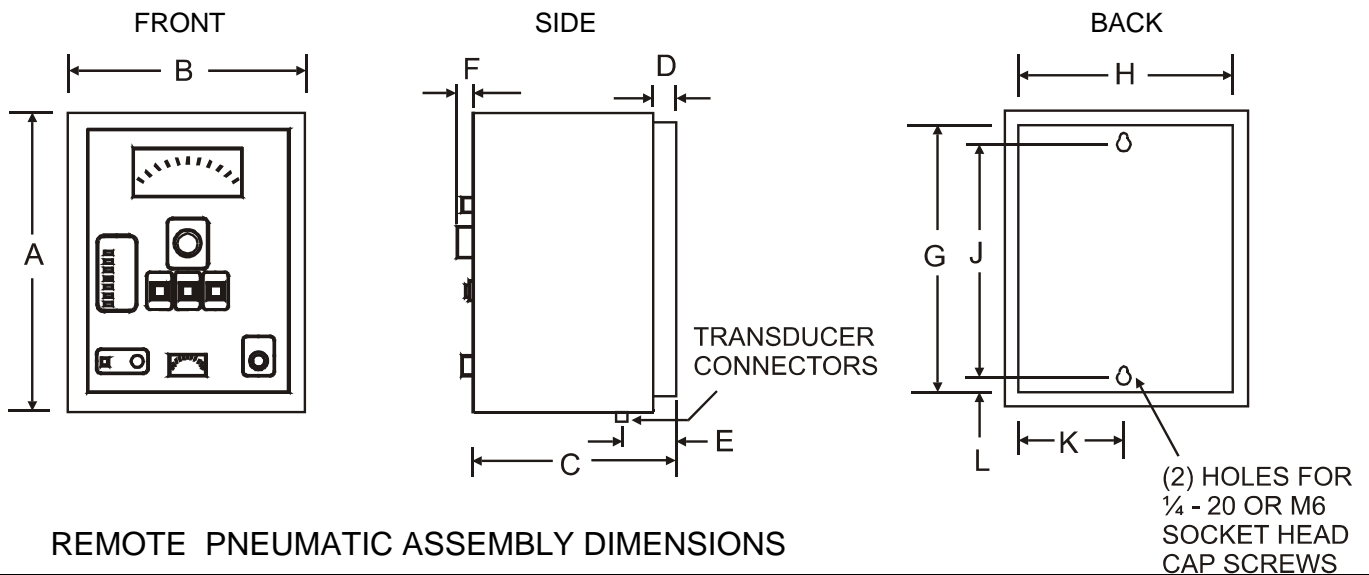

REMOTE PNEUMATIC ASSEMBLY DIMENSIONS

	A	B	C	D	E	F	G
inch	2.0	4.5	8.0	3.0	6.0	2.0	.56
mm	51	114	203	76	152	51	14

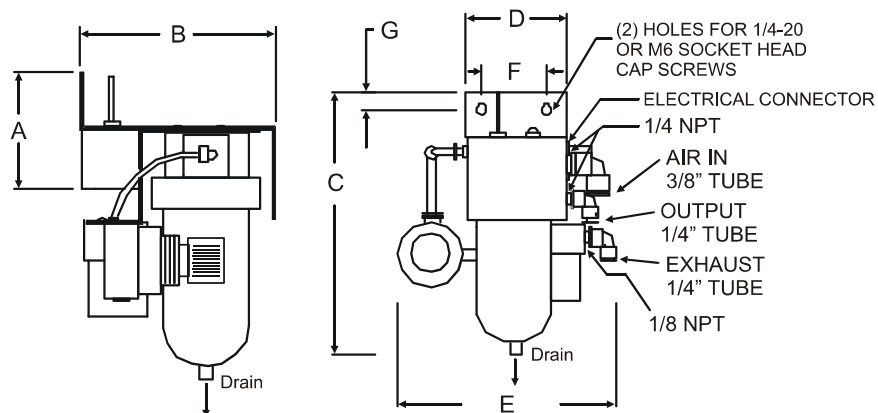

Figure 3 - DIMENSIONS

2.1 INSTALLING THE ENCLOSURE

Select a location on the machine frame or a wall that will be convenient for the machine operator to operate the controller and to see the tension meter easily. Be sure the location is free of vibration, and is dry and clean. Take care to choose a place that the controller won't be struck and damaged by anything or anyone.

The enclosure is fastened to the mounting surface you have chosen by two socket head cap screws. Install the screws in the mounting surface as shown below. Leave them loose about 6 turns. Position the keyholes in the back panel of the enclosure over the screws and slide it down until it locks in place. The cover must be removed to tighten the mounting screws. (See Figure 5)

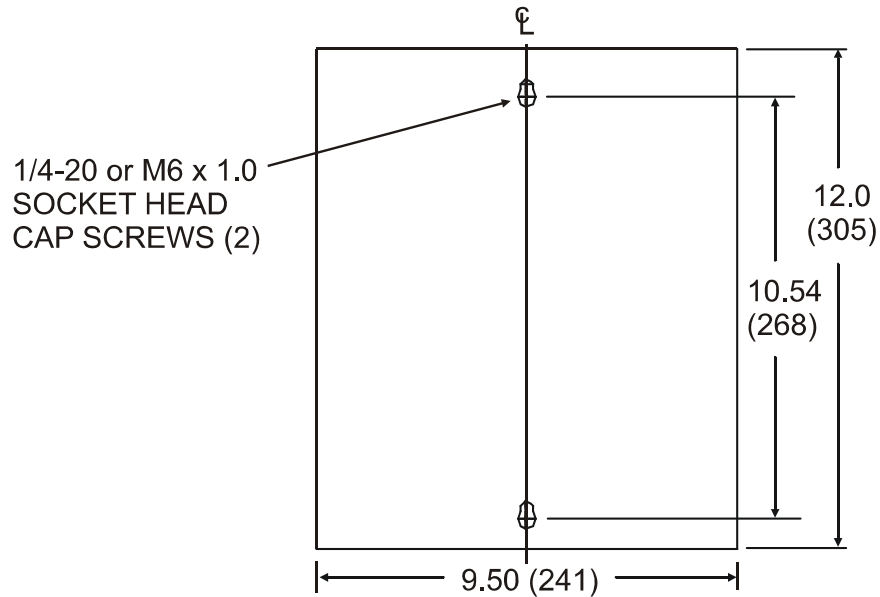

Figure 4 - MOUNTING SCREW LOCATIONS

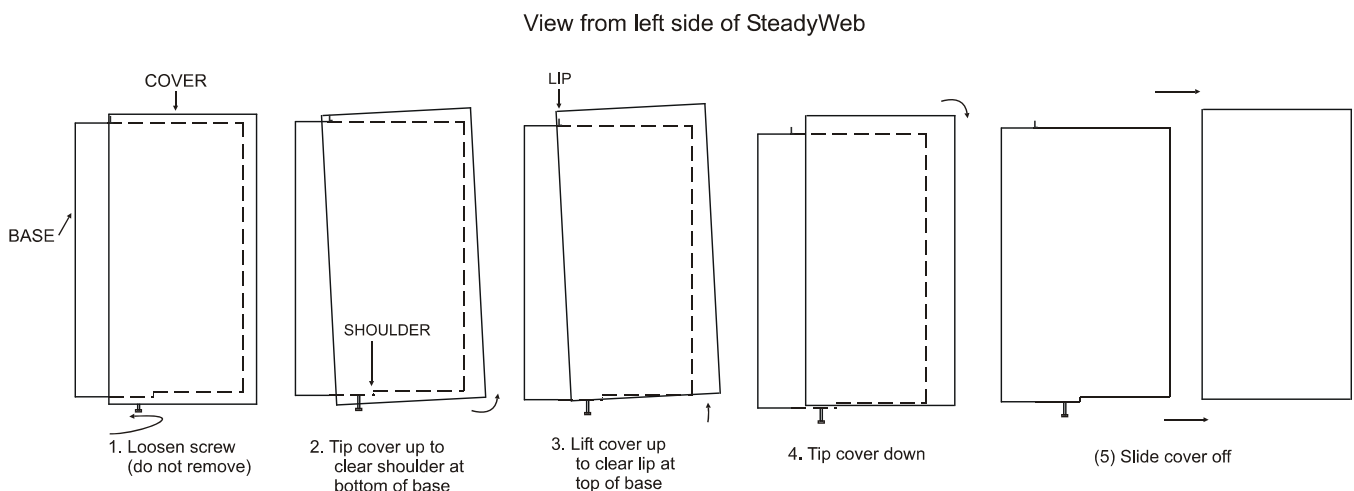

Figure 5 - COVER REMOVAL

After removing the cover, swing the front panel out by first loosening the two screws on the right side top and bottom corners 1/4 turn CCW. Use a hex wrench to tighten the two enclosure mounting screws.

2.2 ELECTRICAL CONNECTIONS

Refer to the drawing below for electrical connections. If your controller has any optional equipment, refer to Section 2.3 or Appendix D of this manual for the appropriate connections. TB201, TB203 and TB204 are located on the Power Board.

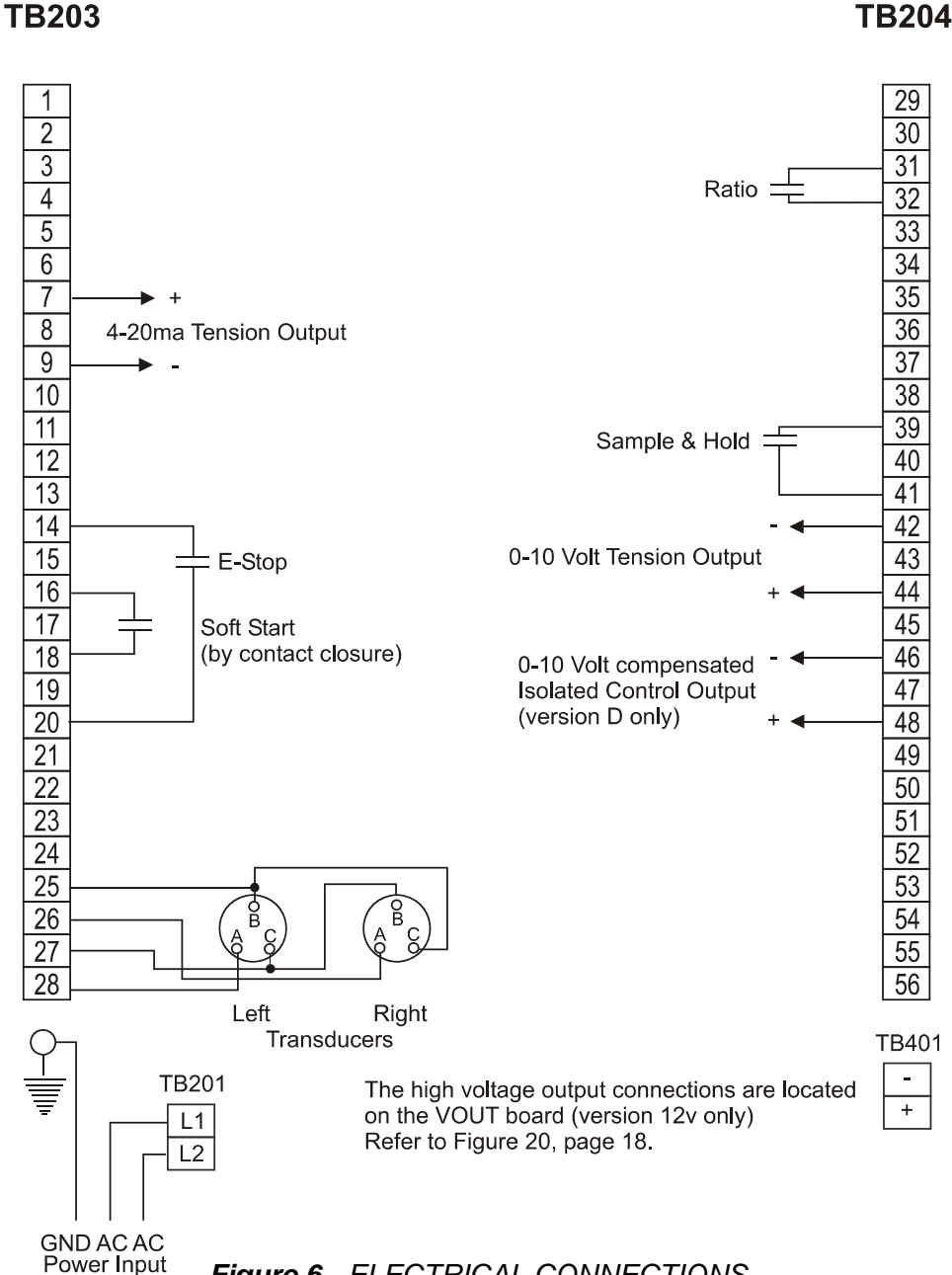

Figure 6 - ELECTRICAL CONNECTIONS

NOTE: The tension transducers are usually connected to the controller by two 3 pin Amphenol connectors mounted on the bottom of the enclosure. However they may be hard-wired directly to the terminal strips as shown above, if desired.

2.3 ELECTRICAL CONNECTIONS OF OPTIONS

TB203

TB204

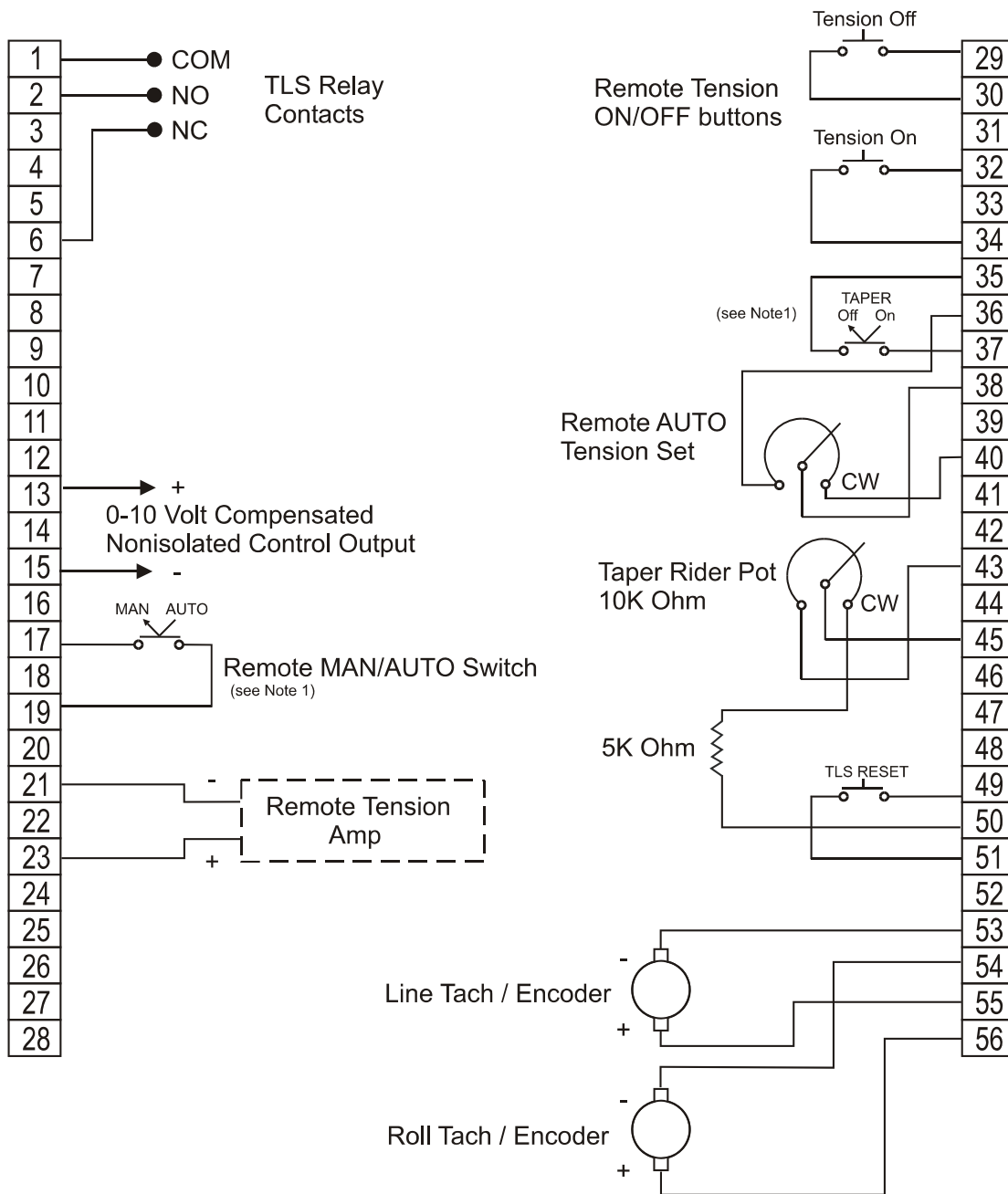

Note1: Must disconnect the front panel device of the same name

Figure 7 - ELECTRICAL CONNECTIONS OF OPTIONS

In addition to the standard enclosure, all SteadyWeb controllers are available in two optional enclosure configurations, H6 and CC. These are normally used by OEMs who wish to integrate the controller into their own electrical enclosures.

3.0 H6 ENCLOSURE CONFIGURATION

The H6 (Harness, 6 ft. long) configuration consists of the standard enclosure with the cover omitted, and the front panel removed and connected to the controller by a harness or ribbon cable. A special cover plate takes the place of the front panel on the controller. This arrangement permits installation of the controller inside another enclosure with the front panel mounted in a rectangular cutout in the face of the enclosure.

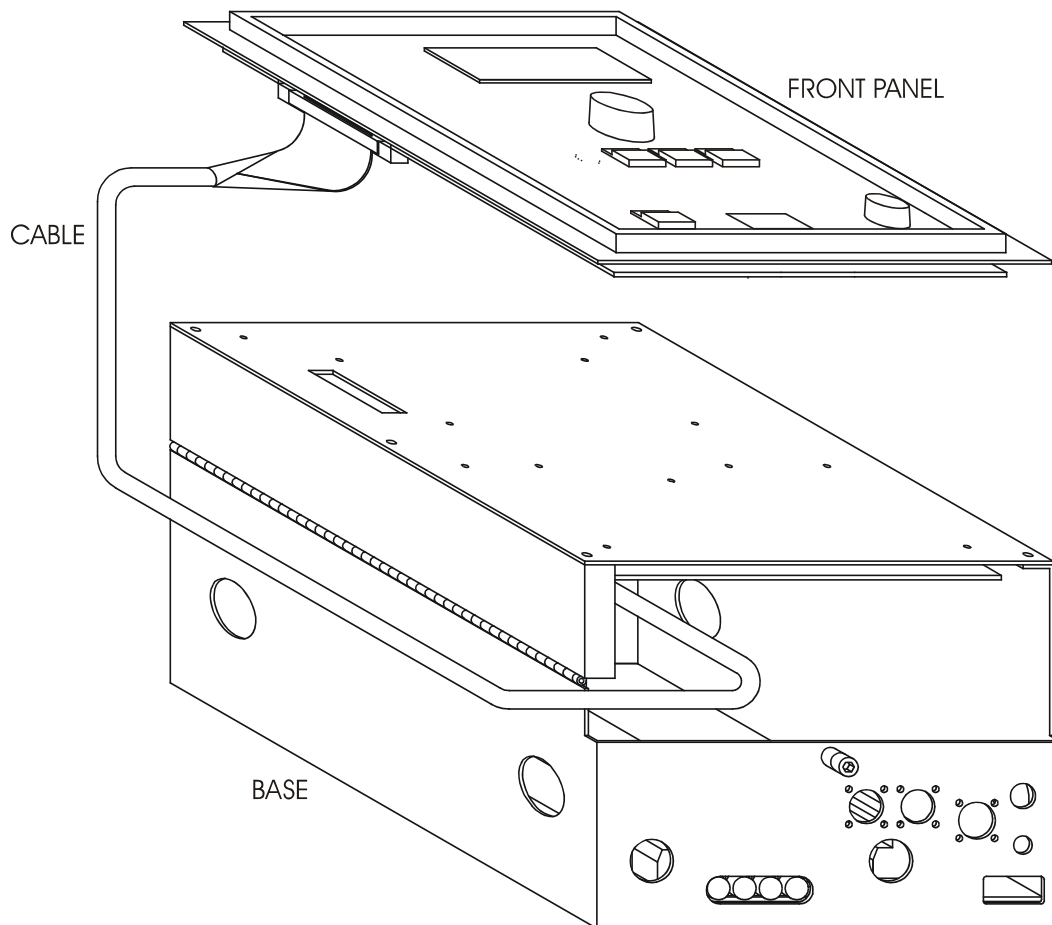

Figure 8 - REMOTE OPERATOR DEVICE CONFIGURATION

DIMENSIONS OF H6 ENCLOSURE CONFIGURATION.

	G	H	J	M	N	P	Q	R
inch	11.78	9.41	10.54	11.24	10.60	10.51	9.31	8.78
mm	299	239	268	285	269	267	236	223

	S	T	U	V	W	X	Y	Z	AA
inch	8.09	.163 Dia Typ 2	.19 Dia Typ 2	.40	.65	1.24	.28	1.58	7.35
mm	205	4,1	4,8	10	17	31	7	40	184

FRONT PANEL

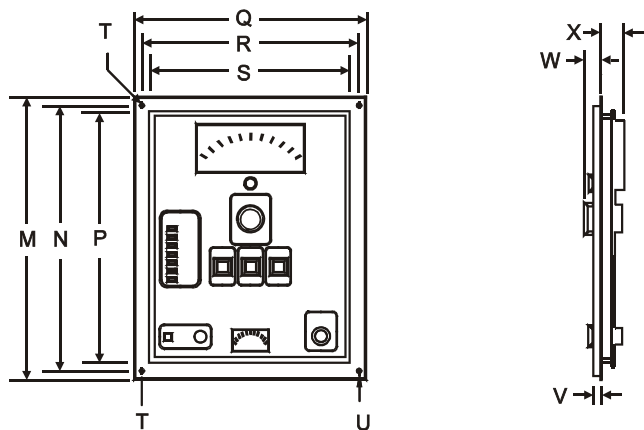

PANEL CUTOUT SIZE - 8 X 10 9/16 (203.2mm X 268.3mm)

BASE

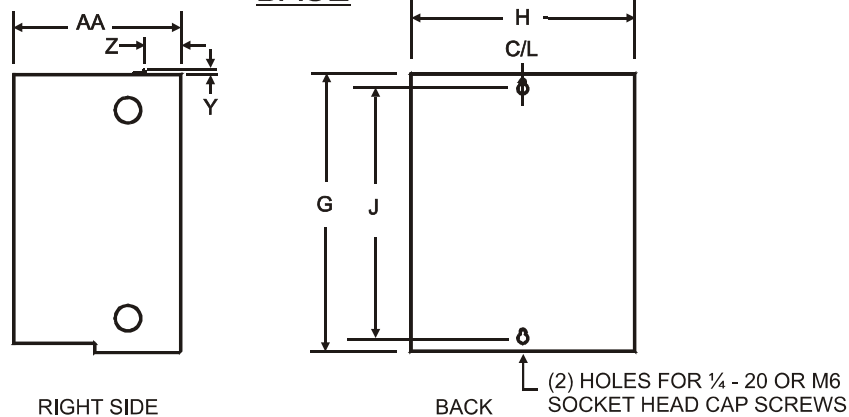

Figure 9 - DIMENSIONS OF H6

ELECTRICAL CONNECTIONS OF H6 CONFIGURATION.

All electrical connections are made in the usual way at the standard terminal strips on the controller Power board. See Sections 2.2 and 2.3, Appendices D and E.

3.1 CC ENCLOSURE CONFIGURATION

The CC (Chassis Configuration) also uses the basic SteadyWeb enclosure with the cover omitted. The front panel is also omitted. So the user must provide all operator devices. A special cover plate takes the place of the front panel on the controller. An interface card is mounted on the cover plate. The card contains a terminal strip for connection to the external operator devices. All other electrical connections are made in the usual way at the standard terminal strips on the controller Power Board.

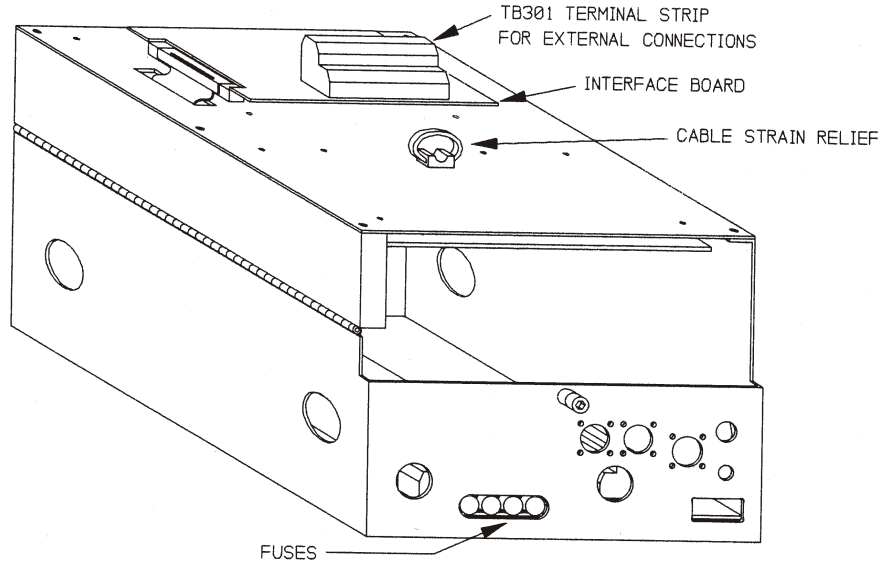

Figure 10 - CHASSIS CONFIGURATION (CC)

DIMENSIONS OF CC ENCLOSURE CONFIGURATION.

	G	H	J	Y	Z	AA
inch	11.78	9.41	10.54	.28	1.58	7.35
mm	299	239	268	7	40	184

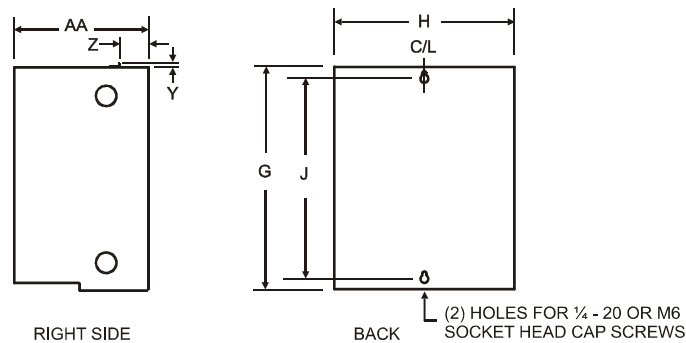

Figure 11 - DIMENSIONS OF CC CONFIGURATION

ELECTRICAL CONNECTIONS OF CC CONFIGURATION - POWER BOARD CONNECTIONS

(See previous page for connections to the Interface Board)

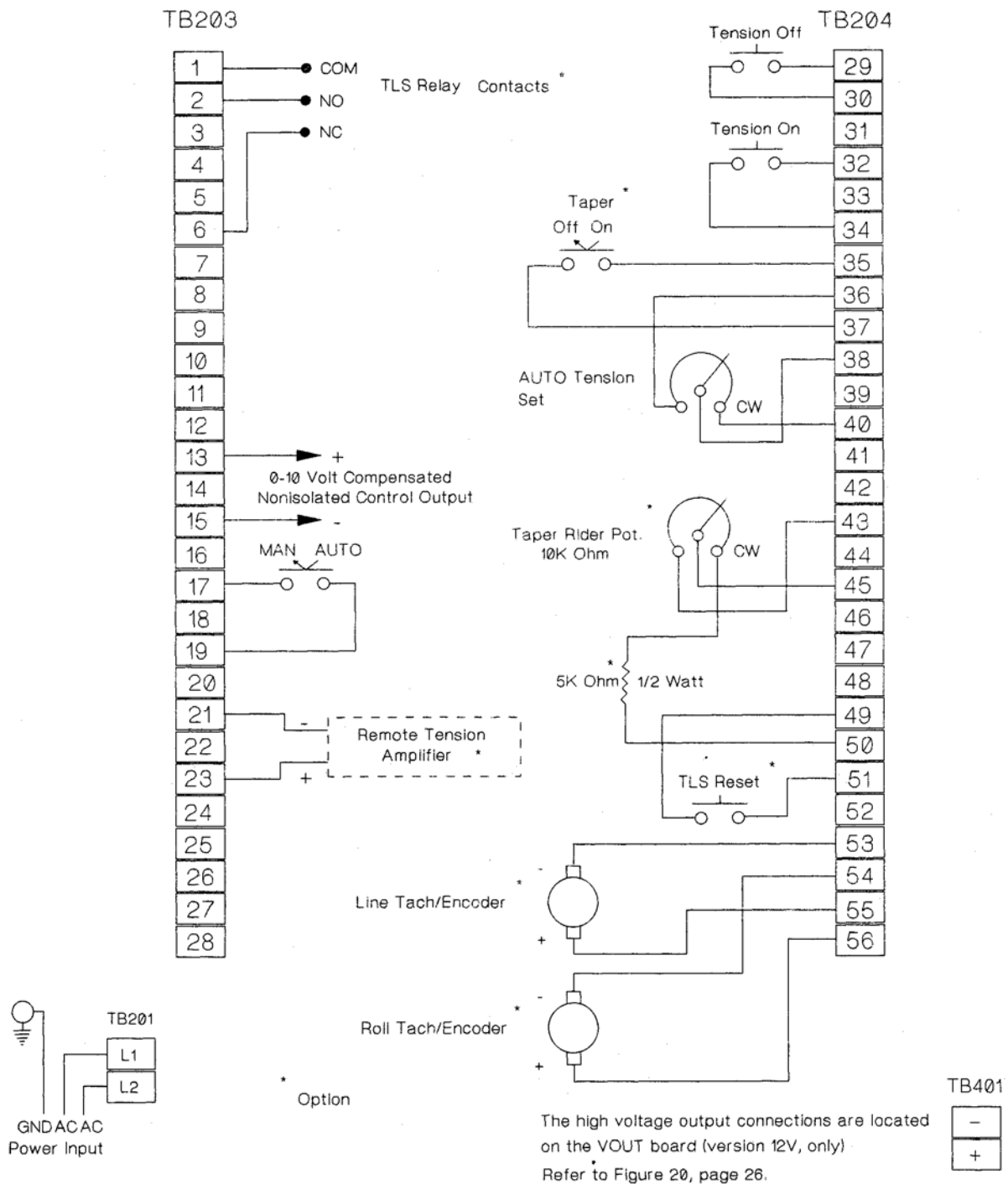

Figure 12B - ELECTRICAL CONNECTIONS OF CC CONFIG. on POWER BOARD.

SECTION 4

CALIBRATING THE TENSION METER

(See Section 6.4 to calibrate the optional Digital Meter)

4.0 MECHANICALLY ZERO THE TENSION METER

This step is only necessary if the tension meter needle does not rest on 0 when the controller power is turned off.

Push the POWER button to turn off power to the controller. Remove the controller cover. Swing the front panel out so the Controller board is accessible. Insert a small screwdriver through the meter zero-screw access hole in the Controller board, turn the adjustment screw on the rear of the meter as required to set the meter needle at 0 on the scale. (See section 6.4 to calibrate the optional digital meter.)

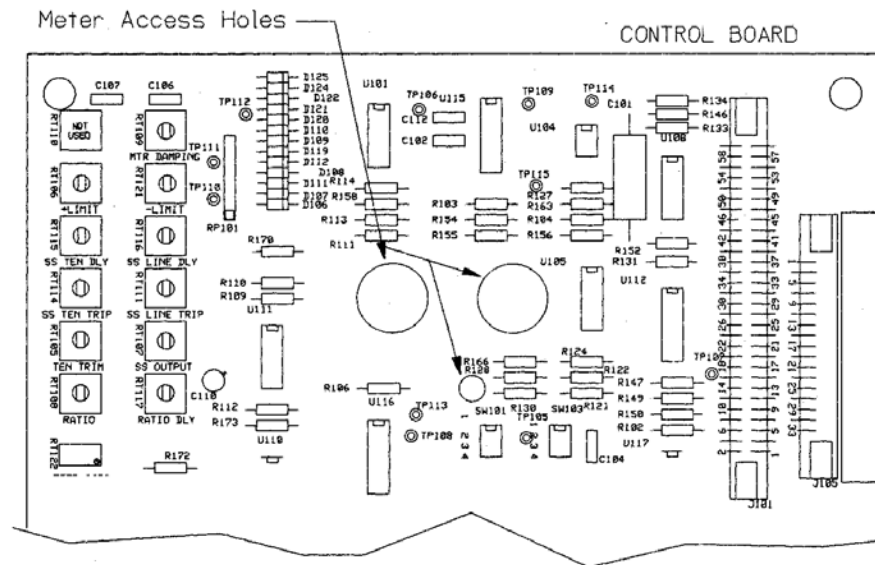

Figure 13 - METER ACCESS HOLES

4.1 CALIBRATE THE METER FOR ACCURACY

(Refer to Figure 16 or 41 for adjustment pots.)

- Find an object of known weight at least as heavy as 25% of the tension meter full scale number. (A fish scale can also be used). Get a length of rope, wire or cable about 15 ft.(3M) long.
- If it has not been done already, remove the controller cover and swing out the front panel so the Control card is accessible.
- Push the POWER button to turn on power to the controller.
- Turn the CAL A pot. clockwise 5 turns (This makes the ZERO pot. setting more accurate). Turn the ZERO A pot. as required to set the meter needle at 0.
- Fasten one end of the rope in the machine and thread the other end around the transducer roll in exactly the same path as the web will take. Be sure it does not pass around any driven rolls, drag bars, or anything else that can affect tension. Refer to the Figure on the following page.

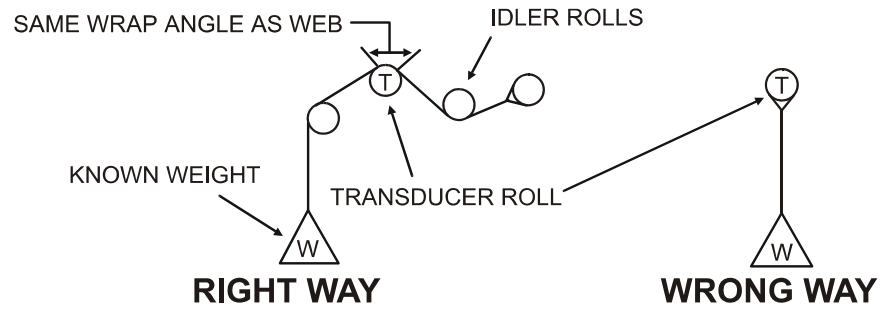

Figure 14 - WEB PATH FOR METER CALIBRATION

- f) Attach the weight to the free end of the rope as shown above. Adjust the CAL A pot. as required to set the meter needle at the value of the weight.
- g) Remove the weight and observe the tension meter. If the needle is not on 0, adjust the ZERO A pot. as needed. Repeat step f.
- h) Repeat steps f and g if needed.

TENSION METER CALIBRATION IS COMPLETED.

NOTE: The ZERO B and CAL B pots. are only used with the Dual Calibration (DC) option.

YOUR STEADYWEB CONTROLLER HAS BEEN PROPERLY CONFIGURED AT THE FACTORY. IT SHOULD NOT BE NECESSARY TO MAKE ANY CHANGES. USE THIS SECTION ONLY TO VERIFY THE CONFIGURATION OR TO RECONFIGURE THE CONTROLLER IF YOUR APPLICATION REQUIREMENTS CHANGE.

5.0 TENSION ZONES

Tension zones are created by driven or braked nip rolls, drag bars, braked or driven unwind or rewind shafts, or anything else that can increase or decrease web tension. One of these elements is at each end of every tension zone.

Almost all machines that process a continuous web have more than one tension zone. The SteadyWeb controller can be used in any tension zone, however it may need to be configured for the zone it will be used in. The information below will be used later to determine the correct configuration.

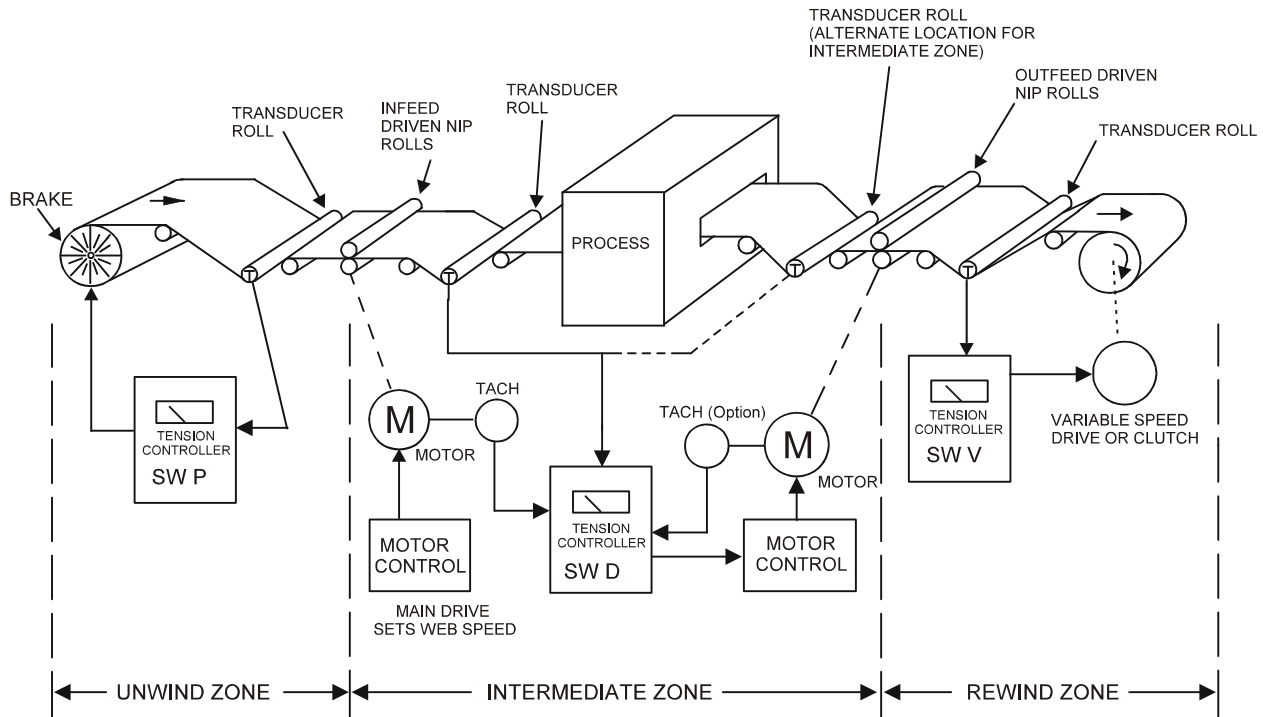

Figure 15 - TENSION ZONES

5.1 THE CONTROL BOARD

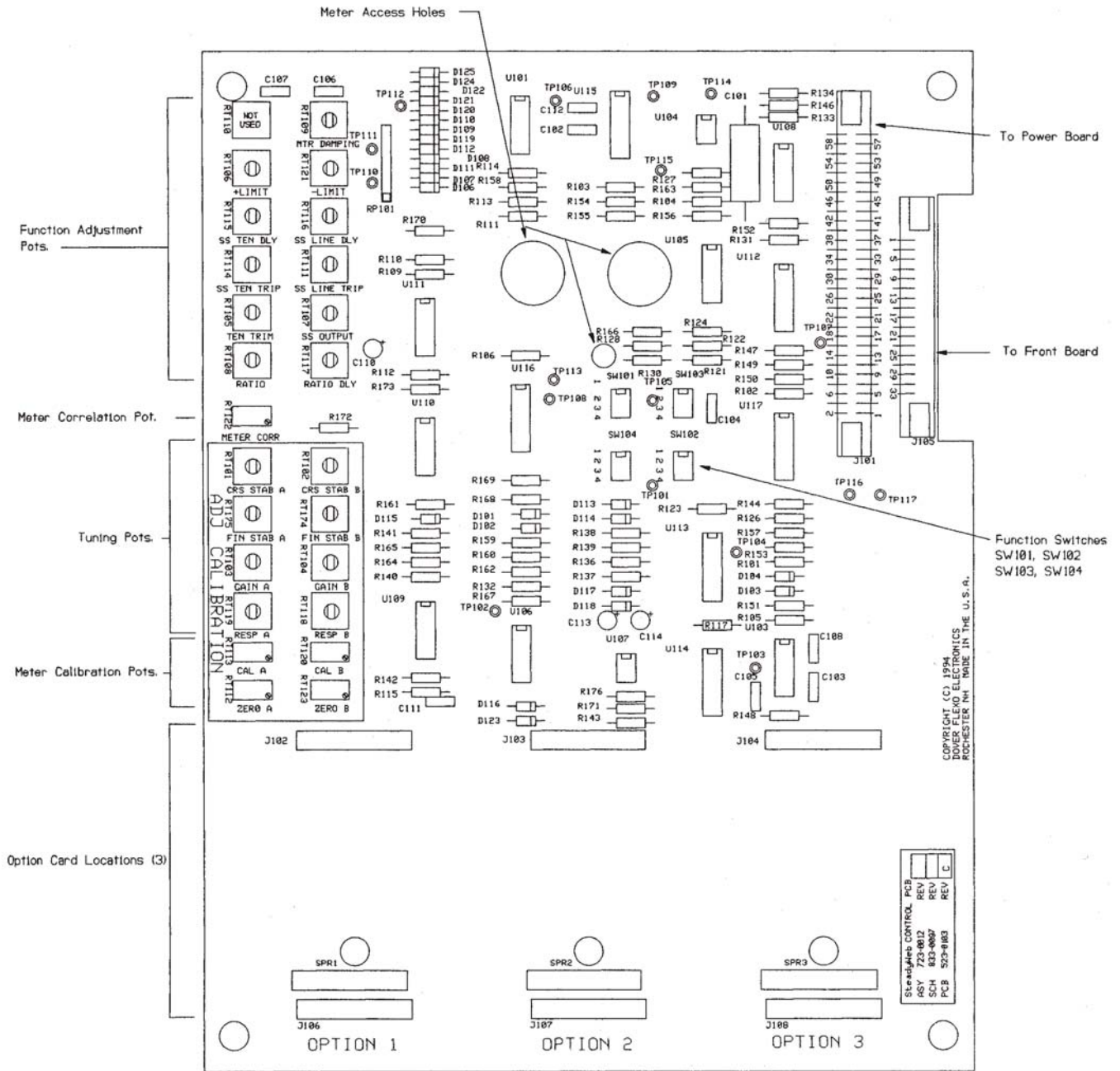

Figure 16 - CONTROL BOARD

5.2 THE POWER BOARD

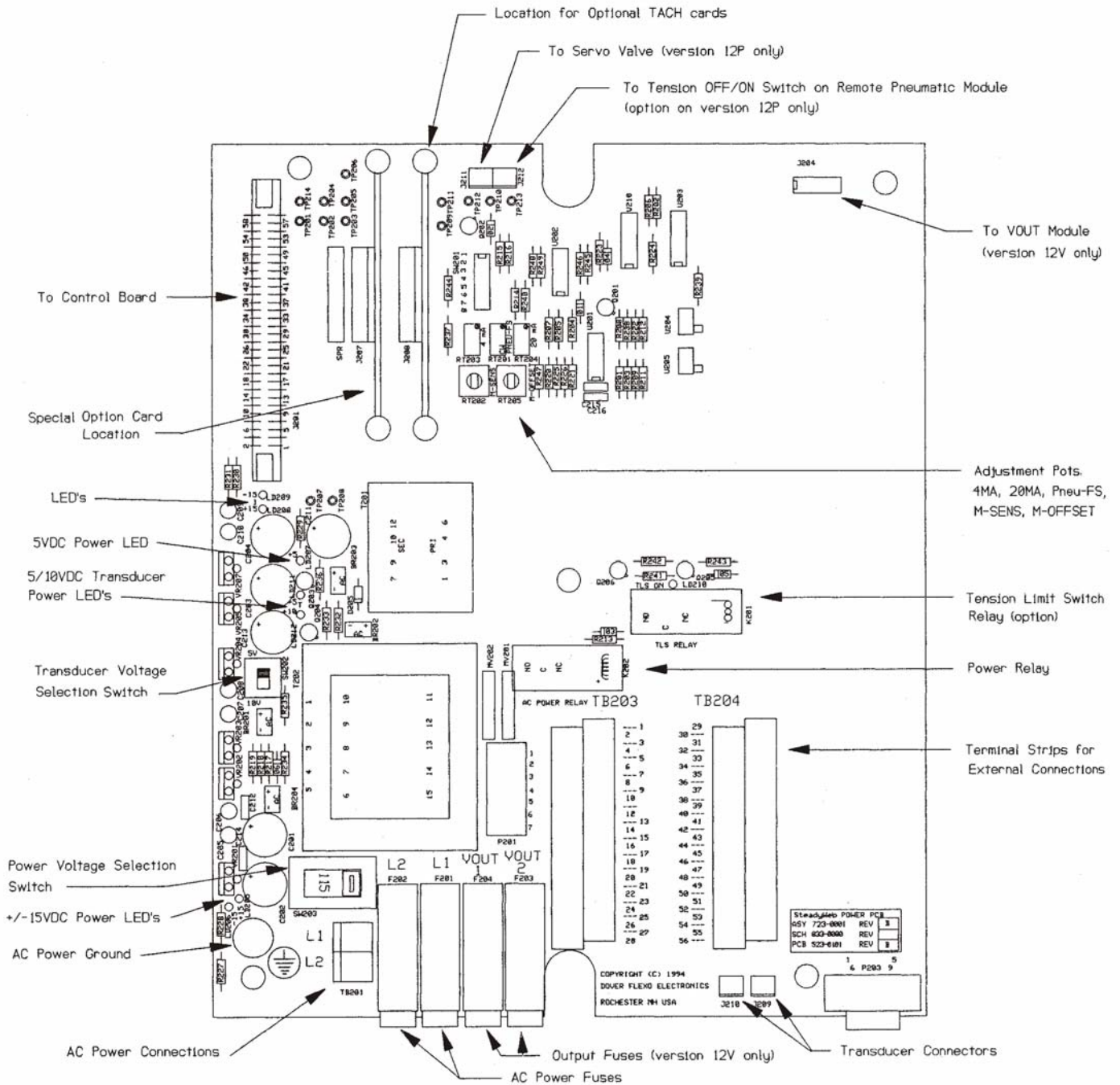

Figure 17 - POWER BOARD

5.3 POWER VOLTAGE SELECTION (See Figure 17, page 22)

The SteadyWeb controller is designed to operate on either 115v-60Hz or 230v-50/60Hz power. Select the correct voltage for your application with the Power Selector Switch, SW203. The left position selects 230v; the right position selects 115v.

CAUTION! The wrong selection will damage the controller!

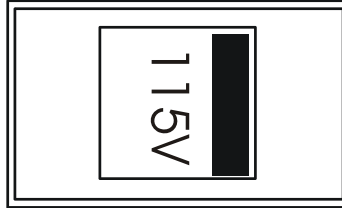

Figure 18 - POWER SWITCH

5.4 CONTROL VOLTAGE SELECTION AND ADJUSTMENT

(See page 4 for description, Figure 16 for switch and adjustments)

This output drives the Pneumatic output module and the High Voltage output module, when used. It is also drives the isolated 10 volt output module on Version 12D controllers. Set the -LIMIT and +LIMIT adjustments and the SW103 DIP switches as follows:

a) Refer to the information below to set the SW103 switches.

SW103 SWITCHES		
0 TO +10 VOLTS	0 TO -10 VOLTS	-10 TO +10 VOLTS
1 - NA	1 - NA	1 - NA
2 - NA	2 - NA	2 - NA
3 - Closed	3 - Open	3 - Open
4 - Open	4 - Closed	4 - Open

NA = Not Applicable

b) Set the +LIMIT pot.(RT106). Set the SW103 switches as shown for the 0 to +10 Volt output. With the tension meter reading 0 and the AUTO mode ON, turn the AUTO set pot. clockwise to turn the output of the controller full on. Turn the TEN TRIM pot.(RT105) fully clockwise so the output will be maximum.

Measure voltage between test points TP107 (+) and TP117. Adjust the +LIMIT pot. for 10 volts.

- c) Set the -LIMIT pot.(RT121). It is necessary to set this pot. only if the 0 to -10 volt or the -10 to +10 volt output is to be used.

Set the SW103 switches as shown for the 0 to -10 Volt output. With the tension meter reading 0 and the AUTO mode ON, turn the AUTO set pot. clockwise to turn the output of the controller full on. Turn the TEN TRIM pot.(RT105) fully clockwise so the output will be maximum.

Measure voltage between test points TP117(+) and TP107. Adjust the -LIMIT pot. for 10 volts.

- d) Set the SW103 switches as required for the control voltage desired. For all SteadyWeb controllers having pneumatic (12P) or high voltage outputs (12V) set the switches as shown for the 0 to +10 volt output.

5.5 4-20mA or 0-20mA TENSION SIGNAL OUTPUT

(See Page 4 for description, Figure 17 for switches)

This current output is proportional to tension, not controller output. Select between 4-20 or 0-20 milliamper range. Used as a tension input to data collection systems, computers or drive systems.

- a) The tension meter **MUST** be correctly calibrated before calibrating this current output.
- b) Verify that the 0-10 volt tension output produces 10 volts DC when the tension meter reads full scale (100%). Measure at terminal strip TB203, terminals 42(-) and 44(+). If not, calibrate the meter. See Section 4. Use the ZERO A pot. to adjust the tension meter to full scale(100%), or to 0 for the following procedures, as needed. Remove the web from the transducer roll to bring the tension meter to 0.
- c) On the Power Board, connect a digital voltmeter to test points TP212(+) and TP206(-). Close switch 8 on SW201. (This connects a 100 ohm resistor across the current output.)
- d) For 4-20mA output range, adjust the 4MA pot. (RT204) so the voltmeter reads 0.4 volts when the tension meter reads 0. Then adjust the 20MA pot. (RT203) for 2.0 volts when the tension meter reads 100% (full scale).
- e) For 0-20mA output range, adjust the 4MA pot. (RT204) so the voltmeter reads 0.0 volts when the tension meter reads 0. Then adjust the 20MA pot. (RT203) for 2.0 volts when the tension meter reads 100% (full scale).
- f) Set the tension meter to 0. Check the low end of the current range. The voltage across the test points should be 0.4 or 0.0 volts as previously set. If not, adjust the 4MA pot. as needed.
- g) Open switch 8 on SW201 to enable the current output. Set the tension meter to 0 with the ZERO A pot.

5.6 EMERGENCY STOP (See Page 4 for description, Figure 17 for switches)

An external contact is required. The controller will be in the Emergency Stop mode as long as the contact is closed and will go to the AUTO mode as soon as it opens. No adjustments are required. Works in the MANUAL control mode, too.

- a) Choose between zero output and full output upon actuation. The status light on the front panel will light when Emergency Stop is activated.
- b) Connect the external contact as shown below.

TB203 (partial view shown)

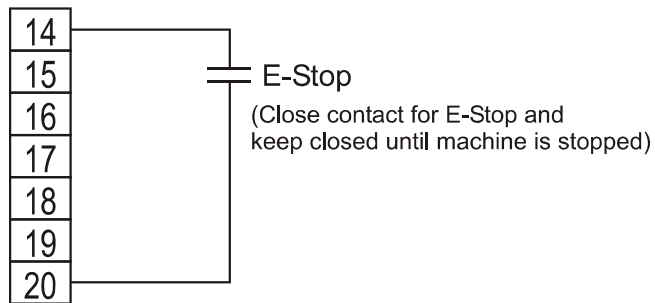

Figure 19 - E-STOP ELECTRICAL CONNECTIONS

- c) Set the SW201 switches as follows:

SW201 SWITCHES	
FULL OUTPUT	ZERO OUTPUT
1 - NA	1 - NA
2 - NA	2 - NA
3 - NA	3 - NA
4 - NA	4 - NA
5 - NA	5 - NA
6 - NA	6 - NA
7 - Open	7 - Closed
8 - NA	8 - NA

NA = Not Applicable

5.7 HIGH VOLTAGE OUTPUT MODULE

(SteadyWeb Version 12V only, description on Page 1)

This module, called the V-OUT card, contains the SCR bridge and driver circuitry to produce the output voltage of the controller. It is designed to operate with either 115v or 230v input power and to produce 90vdc, 45vdc, 24vdc, or 180vdc outputs. (The 180 volt output requires 230vac input.)

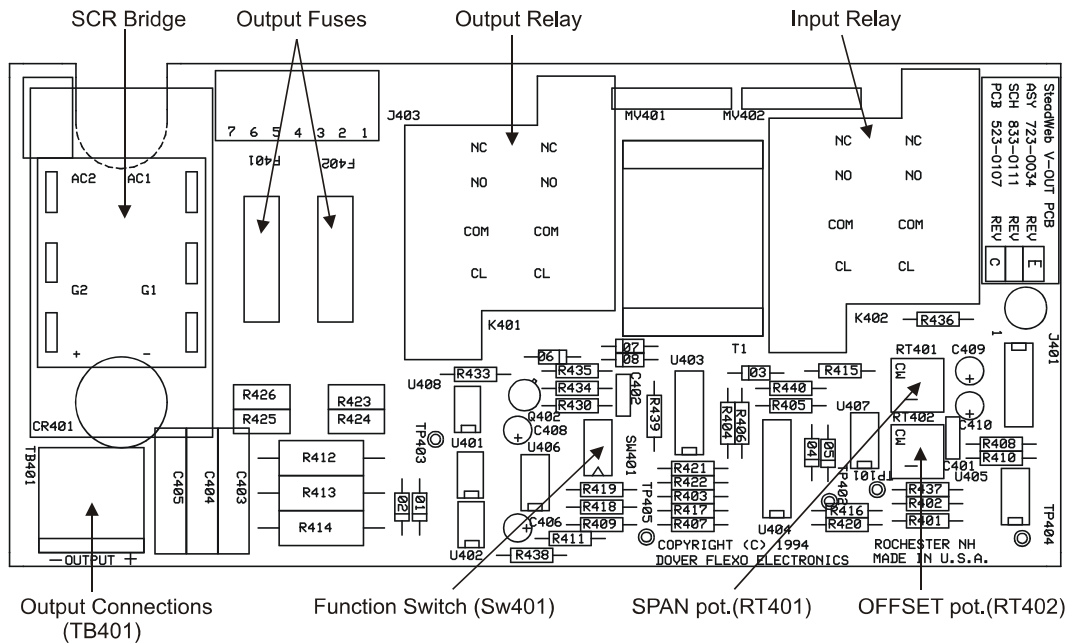

Figure 20 - V-OUT MODULE

a) To select the input and output voltages, set the SW401 switches as follows:

SW401 SWITCHES				
0-90VDC Out 115VAC In	0-45VDC Out 115VAC In	0-24VDC Out 115VAC In	0-90VDC Out 230VAC In	0-45VDC Out 230VAC In
1 - Open	1 - Open	1 - Closed	1 - Open	1 - Closed
2 - Closed	2 - Closed	2 - Open	2 - Closed	2 - Open
3 - Open	3 - Open	3 - Open	3 - Open	3 - Open
4 - Open	4 - Closed	4 - Closed	4 - Closed	4 - Closed
0-24VDC Out 230VAC In	<-- THIS INPUT/OUTPUT IS FACTORY <-- INSTALLED			0-180VDC Out 230VAC In
1 - Open	Component changes and additions are required!			1 - Open
2 - Closed				2 - Closed
3 - Open				3 - Open
4 - Open				4 - Open

The SPAN and OFFSET pots.(RT401 and RT402) are set at the factory and should not require any adjustment. If their settings have been changed, reset them as follows.

- b) Turn power on. Turn Tension on. Switch to MANUAL control mode. Turn the MANUAL pot. all the way counter-clockwise. Connect a voltmeter to the output terminals on the VOUT card.
- c) Turn both SPAN and OFFSET pots. fully clockwise. Observe the voltmeter and turn the OFFSET pot.(RT402) slowly counter-clockwise until the voltmeter reads 0.
- d) Turn the MANUAL pot. fully clockwise. Turn the SPAN pot.(RT401) counter-clockwise until the voltmeter reads the output selected in step a) above.

5.8 METER CORRELATION (See Page 4 for description, Figure 16 for adjustment)

This function matches the signals from the AUTO set pot. and the transducers to compatible magnitudes. If set too low, the controller goes to full output. If too high, there is no output.

- a) Be sure the tension meter has been properly calibrated. (refer to Section 4) Set the AUTO set pot. at 0. Remove the web from the transducer roll so the tension meter reads 0. Set the GAIN pot.(RT103) to 100%. (fully clockwise) Measure the voltage between test points TP105 (+) and TP117.

Set the METER CORR pot.(RT122) to 0.60 VDC. If controller has reverse output (see Sections 1.4, page 4 and 5.10, page 27) set the voltage to -0.60 VDC. Return the GAIN pot. to its original setting.

If the correlation between the tension meter and the AUTO pot. is satisfactory, quit here. If not, proceed to Step b.

- b) Run the machine at normal speed, with any normal tension showing on the meter. Be sure the controller is in the AUTOMATIC control mode. Note the position of the AUTO pot. If it is lower than the meter needle position, on a % basis, turn the METER CORR pot. (RT122) clockwise a small amount (If higher, turn it counterclockwise). Then turn the AUTO pot. to return to the original tension. Repeat this procedure using small adjustments so as not to disturb the web too much, until the positions of the AUTO pot. and the meter needle are the same, on a % basis. That is; if the AUTO pot. is at 5, the meter needle should be at 50% of full scale.

5.9 METER DAMPING (See Page 4 for description, Figure 16 for adjustment)

This adjustment steadies the analog tension meter needle. It also works with the optional digital meter. Turn the MTR DAMPING pot. (RT109) CW to stabilize the meter reading. This only affects the meter. The tension signal to the regulator circuit is not damped.

5.10 OUTPUT DIRECTION (See Page 4 for description, Figure 16 for switches)

Reverse output is used only when the tension transducers are installed after (downstream of) a driven nip which they control. Set the SW101 switches as follows:

SW101 SWITCHES	
NORMAL OUTPUT	REVERSE OUTPUT
1 - Open	1 - Closed
2 - Closed	2 - Open
3 - NA	3 - NA
4 - NA	4 - NA

5.11 OUTPUT METER (See Page 4 for description)

The output meter can be set to read zero at the left end of the scale or at the center of the scale. Normally, zero is at the left. But in Version 12D controllers having a -10 to +10 volt output and zero-center meter, it should be set for center zero.

a) Set the SW201 switches as follows:

SW201 SWITCHES	
LEFT ZERO	CENTER ZERO
1 - NA	1 - NA
2 - NA	2 - NA
3 - NA	3 - NA
4 - NA	4 - NA
5 - Open	5 - Closed
6 - Open	6 - Closed
7 - NA	7 - NA
8 - NA	8 - NA

- b) The +LIMIT and/or -LIMIT pots. must be correctly set before making the M-SENS adjustment. See Section 5.4 for procedure.
- c) If the center-zero meter is being used, set the M-OFFSET pot.(RT205) now. With the controller in the AUTO mode, turn the AUTO set pot. fully counterclockwise to turn the output off. Adjust the M-OFFSET pot. so the output meter reads 0.
- d) Set the M SENS pot.(RT202) so the output meter reads 100% at full output. Turn the TEN TRIM pot. on the Control board fully clockwise to enable full output. Adjust the M-SENS pot. so the output meter reads 100%.

5.12 PNEUMATIC OUTPUT MODULE (SteadyWeb Version 12P only)

(See Figure 16 for adjustment, see Page 1 for description)

The air pressure regulator is preset to 80psi (5,5 bar). No further adjustment is needed. Set the PNEU FS pot.(RT201) for 75 psi maximum output.

- a) Before making this adjustment, be sure the +LIMIT pot. has been set correctly. See Section 5.4 for procedure.
- b) Remove the web from the transducer roll so the tension meter reads 0. Install an air pressure gauge at the controller output.
- c) Turn the TEN TRIM pot.(RT105) on the Control board fully clockwise to enable full output from the controller. Put the controller in the AUTO mode and turn the AUTO set pot. clockwise to turn the controller fully ON.
- d) Adjust the PNEU FS pot. to get 75psi on the pressure gauge.

5.13 RATIO UP/DOWN (See Page 4 for description, Figure 16 for adjustments)

NOTE: The Ratio function is not normally needed for most applications. Use it only if there is a large tension fluctuation during or directly after the splice.

The output of the controller is locked (see Section 5.17 Sample and Hold following) and then multiplied or divided when an external contact is closed. The output will remain at this modified level as long as the contact remains closed. When it opens, the controller goes into the AUTO control mode, after a time delay. The amount of multiplication or division, called the ratio, is set by the RATIO pot. (RT108). When the pot. is at midrange, the ratio is 1. When it is fully CCW, the ratio is 0.1. When it is fully CW, the ratio is 10. The time delay is set with the RATIO DLY pot (RT117). When fully CW, the delay is about 5 seconds. There is no delay at the fully CCW position. When the Ratio function is active, both the Sample & Hold and the Ratio lights on the front panel will be illuminated.

- a) To set the RATIO and RATIO DLY pots. it is necessary to operate the machine and record the output of the controller at both core and full roll diameters. Use the output meter on the front panel for this.
- b) Turn the RATIO pot. 1/2 turn CW. Turn the RATIO DLY pot. 1/2 turn CW.
- c) Connect the external contact as shown below.

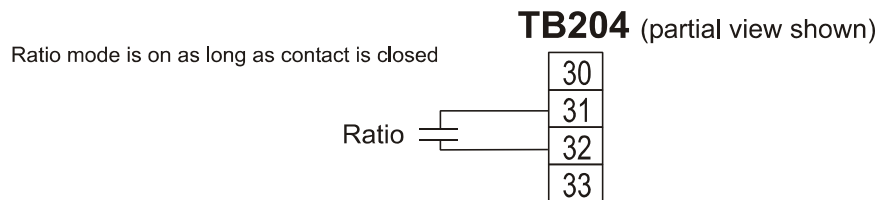

Figure 21 - RATIO CONTACT ELECTRICAL CONNECTIONS

- d) **FOR UNWINDS:** Run the machine slowly with the controller in the AUTO mode and set the tension the same as it was when the core and full roll outputs were measured previously. Start at core diameter. Make the following adjustment before many wraps accumulate on the core.
- e) Close the external Ratio contact to put the controller in the Ratio mode. Turn the RATIO pot. CW until the output meter reads the full roll value recorded earlier.
- f) Perform a flying splice. Adjust the RATIO DLY pot. as needed to keep the controller in the Ratio mode just long enough for the new roll to tag onto the web at the slowest machine speed at which splices will be made.
- g) **FOR REWINDS:** Wind a full roll of material. Then run the machine slowly with the controller in the AUTO mode and set the tension the same as it was when the core and full roll outputs were measured previously. Make the following adjustment at the full roll diameter.
- h) Close the external Ratio contact to put the controller in the Ratio mode. Turn the RATIO pot. CCW until the output meter reads the core diameter value recorded earlier.
- i) Perform a flying splice. Adjust the RATIO DLY pot. as needed to keep the controller in the Ratio mode just long enough for the web to tag onto the core at the slowest machine speed at which splices will be made.

5.14 REMOTE TENSION AMPLIFIER INSTALLED?

(See Page 7 for description, Figure 16 for switches)

The SW102 switches must be set for the presence or absence of the Remote Tension Amplifier option. Set the switches as shown to accept the tension signal from the amplifier inside the controller (local) or the remote amplifier.

SW102 SWITCHES	
LOCAL	REMOTE
1 - Closed	1 - Open
2 - Open	2 - Closed
3 - NA	3 - NA
4 - NA	4 - NA

NA = Not Applicable

5.15 REMOTE TENSION ON/OFF (See Page 5 for description)

This requires two momentary contact N.O. pushbuttons. Connect them as shown below.

TB204 (partial view shown)

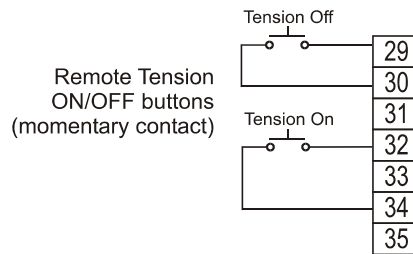

Figure 22 - REMOTE TENSION ON/OFF BUTTON CONNECTIONS

5.16 REMOTE TENSION SET (See Page 5 for description, Figure 16 for switches)

The AUTO mode tension set pot. can be located on the front of the controller (locally) or external (remote) to it. Set the SW102 switches as in the following table:

SW102 SWITCHES	
LOCAL	REMOTE
1 - NA	1 - NA
2 - NA	2 - NA
3 - Closed	3 - Open
4 - Open	4 - Closed

NA = Not Applicable

:

5.17 SAMPLE AND HOLD (See Page 5 for description, Figure 16 for switches)

The output of the controller is measured and then locked at the measured value upon the closure of an external contact. The output remains locked only as long as the contact is closed. The status light on the front panel will light when the output is locked. Connect the contact as shown below.

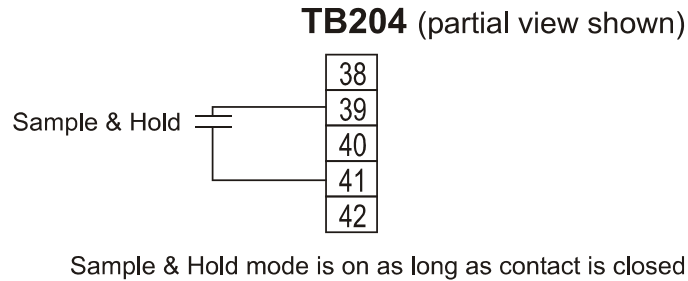

Figure 23 - SAMPLE & HOLD CONTACT

5.18 SOFT START (See Page 5 for description, Figure 16 for switches and adjustments)

Soft start is normally used only in UNWIND zone applications. It can be actuated in one of three ways; 1. by sensing a loss of tension, 2. by closure of an external contact, 3. by sensing machine speed. The status light on the front panel will light when Soft Start is activated.

1. **Actuation by low tension.** This is the standard configuration.

- a) Turn off soft start when the controller is being used to control rewind or intermediate tension because it serves no purpose and it may not be possible to leave soft start. No external electrical connections are needed for actuation. Set SW104 switches as follows:

SW104 SWITCHES	
SS ON	SS OFF
1 - Open	1 - Closed
2 - Open	2 - Open
3 - NA	3 - NA
4 - NA	4 - NA

NA = Not Applicable

If Soft Start is set ON, proceed to Step b, otherwise quit here.

- b) Set the SS OUTPUT pot. (RT107) for the output you want while in Soft Start. The range is about 0 to 100% of maximum output. Turn the pot. CW to increase output. Avoid setting the output higher than the operating tension. It is best to set it low, but high enough to produce enough tension to exceed the trip point tension or the controller may not be able to get out of Soft Start.

- c) Set the SS TEN DLY pot. (RT115) for a short time delay before Soft Start actuates. This eliminates nuisance actuation if tension drops for only a short time. The range is about 0 to 3 seconds. Turn the pot. CW to increase the delay. There is no delay when leaving the Soft Start mode.
- d) Set the SS TEN TRIP pot. (RT114) to the tension which will actuate Soft Start. The range is about 0 to 100% of the tension meter scale. Turn the pot. CW to increase the trip point. Avoid setting the trip point close to your operating tension. Set it much lower, instead. Be sure the SS OUTPUT pot. is set high enough to produce enough tension to exceed the trip point tension.
- e) Set the SS LINE TRIP pot. fully CCW to avoid interference with the SS TEN TRIP pot.

2. Actuation by external contact closure.

- a) Connect the external switch or relay contact as shown. The controller will remain in the Soft Start mode as long as the contact is closed.

TB203 (partial view shown)

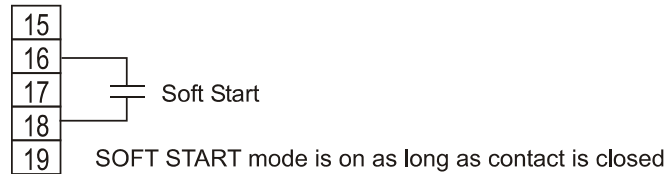

Figure 24 - SOFT START CONNECTIONS

- b) Set the **SW104** switches as follows:

SW104
1 - Open
2 - NA
3 - NA
4 - NA

- c) Set the SS OUTPUT pot.(RT107) for the output you want while in Soft Start. The range is about 0 to 100% of maximum output. Turn the pot. CW to increase output. Avoid setting the output higher than the operating tension. It is best to set it low, but high enough to produce enough tension to exceed the trip point tension or the controller may not be able to get out of Soft Start.

Soft Start actuates immediately upon contact closure. There is no time delay. There are no other adjustments.

3. Actuation by machine speed.

This requires an optional DC Tachometer card or Pulse Tachometer card to provide a machine speed signal. Calibrate the card as described in Section 6 before proceeding with Soft Start set-up.

- a) Set the **SW104** switches as follows:

SW104
1 - Open
2 - NA
3 - NA
4 - NA

- b) Set the SS OUTPUT pot.(RT107) for the output you want while in Soft Start. The range is about 0 to 100% of maximum output. Turn the pot. CW to increase output. Avoid setting the output higher than the operating tension. It is best to set it low, but high enough to produce enough tension to exceed the trip point tension or the controller may not be able to get out of Soft Start.
- c) Set the SS LINE TRIP pot. (RT111) to the machine speed at which you want to actuate Soft Start. The range is about 0 to 100% of maximum line speed. Turn the pot. CW to increase the actuation speed. Set the pot. to about 5%. Do NOT leave it at 0 or Soft Start will be active all the time.
- d) Set the SS LINE DLY pot. (RT116) for a short time delay before Soft Start actuates. This eliminates nuisance actuation if machine speed hovers around the trip point. The range is about 0 to 3 seconds. Turn the pot. CW to increase the delay. There is no delay when leaving the Soft Start mode.
- e) Set the SS TEN TRIP pot. fully CCW to avoid interference with the SS LINE TRIP pot.

5.19 SPEED FOLLOW (See Page 5 for description, Figure 16 for switch)

The SW101 switches must be set to indicate the use or nonuse of the Speed Follow function. Set the switches as in the following table:

SW101 SWITCH				
	1	2	3	4
Speed Follow function OFF	NA	NA	NA	Open
Speed Follow function ON	NA	NA	NA	Closed
Nip roll speed signal OFF	NA	NA	Open	NA
Nip roll speed signal ON	NA	NA	Closed	NA

NA = Not Applicable

5.20 TACHOMETER CARD INSTALLED? (See Page 6 for description, Figure 17 for switch)

A Tachometer Card, Pulse Tachometer Card, or a custom Tachometer card is used with the Taper option, Speed Follow, and one version of Soft Start. The SW201 switches must be set according to the presence or absence of the card. Set the SW201 switches as follows:

SW201 SWITCHES		
NO CARD	STD. CARD PRESENT	CUSTOM CARD PRESENT
1 - Open	1 - Open	1 - Closed
2 - Open	2 - Closed	2 - Open
3 - Open	3 - Open	3 - Closed
4 - Open	4 - Closed	4 - Open
5 - NA	5 - NA	5 - NA
6 - NA	6 - NA	6 - NA
7 - NA	7 - NA	7 - NA
8 - NA	8 - NA	8 - NA

5.21 TLS CARD INSTALLED? (See Page 7 for description, Figure 16 for switches)

The SW104 switches must be set according to the presence or absence of the optional Tension Limit Switch card. Set the SW104 switches as follows:

SW104 SWITCHES	
NO TLS	TLS PRESENT
1 - NA	1 - NA
2 - Open	2 - Open
3 - Closed	3 - Open
4 - Open	4 - Closed

NA = Not Applicable

5.22 TRANSDUCER VOLTAGE (See Page 5 for description, Figure 17 for switch)

The tension transducers can be excited by either 5VDC or 10VDC. The Extended Range option (XR) requires 10VDC. 5VDC is standard.

CAUTION!!

Do NOT use the 10VDC excitation unless the transducers have the XR (extended range) option! The transducers will be DAMAGED!

Set the SW202 switch as follows

- 5VDC - Slide switch UP
- 10VDC - Slide switch DOWN

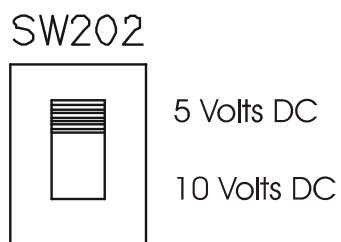

Figure 25 - TRANSDUCER VOLTAGE SWITCH

SECTION 6

SET-UP AND ADJUSTMENT OF OPTIONS

YOUR STEADYWEB CONTROLLER OPTIONS HAVE BEEN PROPERLY SET UP AT THE FACTORY. IT SHOULD NOT BE NECESSARY TO MAKE ANY CHANGES. USE THE INFORMATION IN THIS SECTION TO VERIFY THE SET UP OR TO MAKE MODIFICATIONS IF YOUR REQUIREMENTS CHANGE.

6.0 220 VOLT POWER INPUT (See Page 6 for description)

Refer to Section 5.3 for correct set-up procedure.

6.1 24 VOLT OUTPUT (Version 12V controller only, see Page 6 for description)

Refer to Section 5.7 for correct set-up procedure.

6.2 45 VOLT OUTPUT (Version 12V controller only, see Page 6 for description)

Refer to Section 5.7 for correct set-up procedure.

6.3 DC TACHOMETER CARD (See Page 6 for description)

This card is only used in conjunction with the Taper option, the speed-actuated Soft Start feature, or Speed Follow. It is plugged into the RIGHT hand option socket on the Power board. The left socket is for special cards, if used.

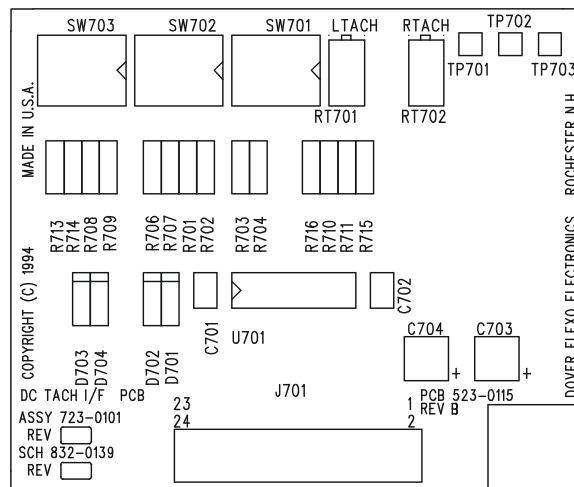

Figure 26 - DC TACH OPTION CARD

There are two +10 volt DC outputs on the card, named LTACH and RTACH. Both are needed for the Taper option, but only LTACH is needed for the speed-actuated Soft Start function. LTACH refers to the line (machine) speed tachometer. RTACH refers to the rewind roll speed tachometer.

The following procedure sets the outputs of the card to +10 volts at maximum machine speed.

- a) Set the SW201 switches on the Power board. Refer to Section 5.20.
- b) Be sure the tachometers are connected to the Power board terminal strip as shown below.

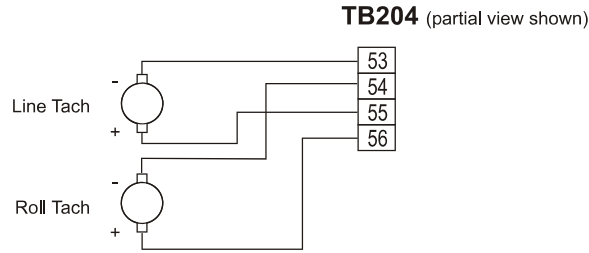

Figure 27 - DC TACHOMETER CONNECTIONS

WARNING!!! To prevent possible damage to the circuit card, set the SW702 and SW703 switches as shown BEFORE installing the card and BEFORE running the machine!

INITIAL SW702 and SW703 SWITCH SETTINGS
1 - Open
2 - Open
3 - Open
4 - Closed

- c) Run the machine at the maximum expected operating speed. Measure the line tachometer voltage and note its polarity. This is called the LTACH voltage. (NOTE: If desired, run the machine at 50% of maximum speed. In this case the LTACH output voltage will be set at 5.0 volts instead of 10 volts, and the RTACH output voltage will be set at 50% of the normal value.)

If the Taper option is to be used, also measure the rewind roll tach voltage AND THE ROLL DIAMETER. Note the polarity. At this point it is necessary to compute the RTACH voltage that will be used later in step e). Use the formula below.

$$\text{RTACH voltage} = (\text{Roll diameter}) / (\text{core diameter}) \times \text{measured voltage}$$

- d) Set the SW701 switches to accommodate the tach polarity measured at terminals 53,55 (LTACH) and 54,56 (RTACH). Use the following charts to set the switches based on which terminal is positive polarity.

SW701 SWITCHES				
	1	2	3	4
LTACH ----- if 55 is + if 53 is +	NA	NA	Open	Closed
	NA	NA	Closed	Open
RTACH ----- if 56 is + if 54 is +	Open	Closed	NA	NA
	Closed	Open	NA	NA

- e) Set the SW702 (LTACH) and SW703 (RTACH) switches to accommodate the voltages measured in step c) above. Both switches are set in exactly the same way. Use the chart below. If the machine was run at half speed, multiply the voltages by 2 and use those values for the switch-setting chart below.

SW702 and SW703 SWITCHES				
VOLTS DC	1	2	3	4
3 - 4	Closed	Open	Open	Open
4 - 16	Open	Closed	Open	Open
16 - 64	Open	Open	Closed	Open
64 - 250	Open	Open	Open	Closed

NA = Not Applicable

Note: Remember to use the computed, not the measured, voltage for RTACH. Multiply the computed voltage by 2 if the machine was run at half speed.

- f) Set the LTACH span pot. Run the machine at maximum speed. Measure the LTACH output voltage at test points TP701 (+) and TP703. Adjust the LTACH Span pot. (RT701) for 10.0 volts.
- g) Set the RTACH span pot. With the machine still running at maximum speed, measure the RTACH output voltage at test points TP702 (+) and TP703. Adjust the RTACH Span pot. (RT702) for 10.0 volts AT THE CORE DIAMETER. As an alternate method, measure the roll diameter and adjust the RTACH Span pot. to a voltage equal to:

$$10 \times (\text{core diameter}) / (\text{roll diameter}).$$

- h) **Note:** If you ran the machine at half speed, set the output voltages at 5.0 volts in steps f) and g) above.

6.4 DIGITAL METER (See Page 6 for description)

Before using the Digital Meter, it must be adjusted to accommodate the expected maximum tension. THIS HAS BEEN DONE AT THE FACTORY. NO CHANGES SHOULD BE NEEDED!

The calibration procedure is the same as for the analog meter. Refer to Section 4, page 18.

CAUTION: When setting the ZERO pot. pay attention to the under-range indicator. The correct setting is where the light just goes out as the ZERO pot. is turned clockwise.

***** OPTIONAL PROCEDURE *****

The range of the Digital Meter is set at the factory, and is based on the maximum tension desired by the user. Use the following procedure to reset the range if you need to read higher tension than the meter was originally set to read.

NOTE: There has been a change of terminology on the circuit board from the original design. The older terminology is in parentheses in the following procedures.

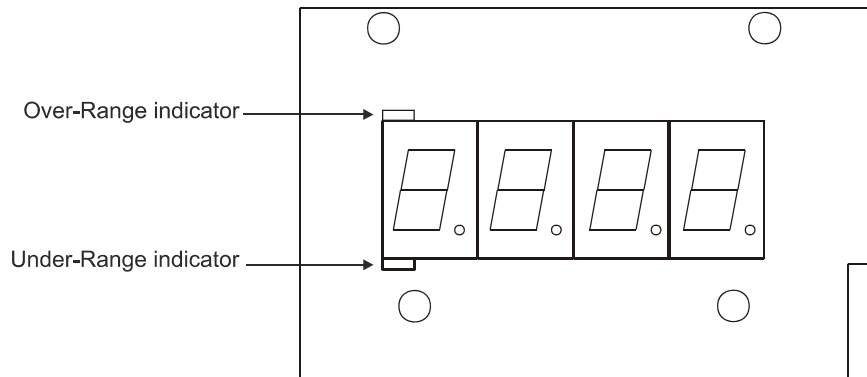

Figure 28 - DIGITAL METER DISPLAY

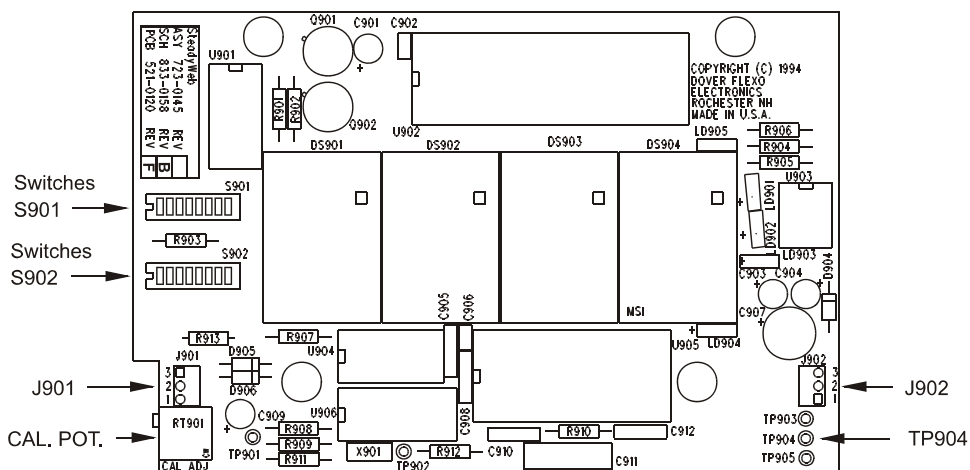

Figure 29 - DIGITAL METER CARD

- Determine the maximum tension to be used. Refer to Specifications, Section 1.3, and select the next highest analog meter scale.
- Determine the number of decimal places for the display. Unless the full-scale tension is very high, it is best to use the maximum of decimal places. This produces a stable display.
- Turn off power. Remove the mounting screws for the Control board to expose the back side of the Digital Meter. Set the S901 and S902 switches as follows:

	SWITCH S901								SWITCH S902							
RANGE	1	2	3	4	5	6	7	8	1	2	3	4	5	6	7	8
0 - 9.9*	O	O	C	O	O	C	O	O	O	O	C	O	O	C	C	--
0 - 99	O	O	C	O	O	C	O	O	O	O	O	O	O	C	C	--
0 - 999	O	C	O	O	C	O	O	C	O	O	O	O	C	C	C	--
0 - 9999	C	O	O	C	O	O	C	O	O	O	O	C	C	C	C	--

- d) Measure the input voltage to the digital meter at pin 1 (+) of socket J901 (S13), and test point TP904 (-) (TP4).
- e) Adjust the ZERO A pot. on the Control board for 10VDC at the points in d) above.
- f) Adjust the CAL ADJ pot.(TR901) (TR1) to set the Digital Meter to the full-scale value selected.
- g) Calibrate the meter according to the procedure in Section 4. **CAUTION:** When setting the ZERO pot. pay attention to the under-range indicator. The correct setting is where the light just goes out as the ZERO pot. is turned clockwise.

6.5 DUAL CALIBRATION

(Dual meter scales and dual stability adjustments, see Page 6 for description)

Refer to Section 4 for procedure to calibrate the tension meter. The ZERO B and CAL B pots. are adjusted in the same way as the ZERO A and CAL A pots. See Section 7 for adjustment of the STAB and RESP pots.

6.6 DUAL TRANSDUCER INPUT (See Section 1.5, Page 6 for description)

The Dual Transducer Input card plugs into the left option socket on the Power board. This card has no adjustments or switches to set. The Dual Calibration option is required. Follow the setup procedure in Sections 4 and 6.5 for each position of the transducer set selector switch. This switch is located to the right of the tension meter on the front panel.

6.7 EXTENDED RANGE (See Page 6 for description)

See Section 5.22, page 34, to set the transducer voltage selection switch. No adjustments or special electrical connections are needed.

6.8 PULSE TACHOMETER CARD (See Page 6 for description, Figure 16 for switches)

This card is only used in conjunction with the Taper option, speed-actuated Soft Start, or Speed Follow. It is plugged into the RIGHT hand option socket on the Power board. The left socket is for special cards, if used.

There are two +10 volt DC outputs on the card, named LTACH and RTACH. Both are needed for the Taper option, but only LTACH is needed for the speed-actuated Soft Start function. LTACH refers to the line (machine) speed pulse tach. RTACH refers to the rewind roll speed pulse tach.

The following procedure sets the outputs of the card to +10 volts at maximum machine speed.

- a) Set the SW201 switches on the Power board. Refer to Section 5.20 on page 34.

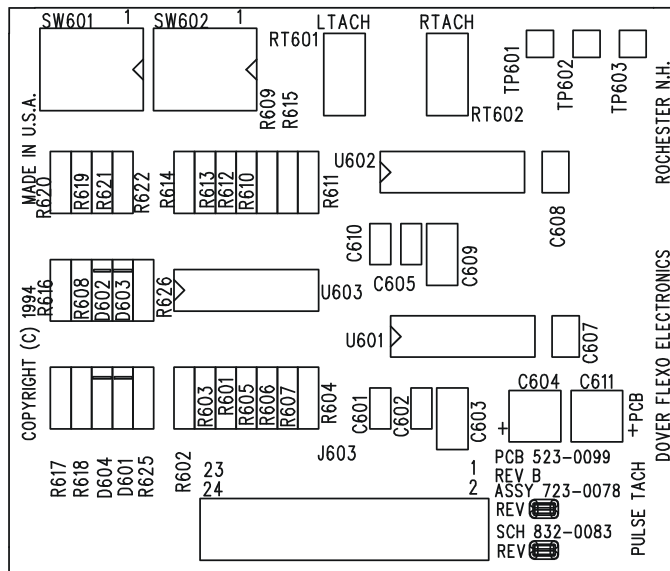

Figure 30 - PULSE TACH OPTION CARD

b) Be sure the pulse tachs are connected to Power board terminal strip as shown below.

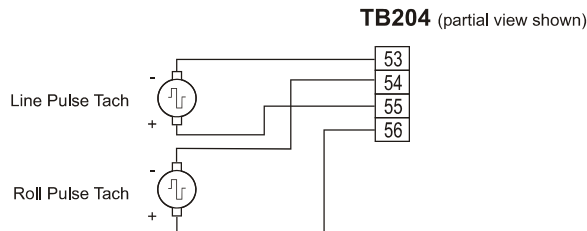

Figure 31 - PULSE TACHOMETER CONNECTIONS

WARNING!! To prevent possible damage to the circuit card, set the SW601 switches as shown below BEFORE installing the card and BEFORE running the machine!

INITIAL SW601 SETTINGS	
1	Closed
2	Open
3	Open
4	Closed

c) Determine the maximum pulse amplitude of pulses from the LTACH and the RTACH pulse tachs. The data sheet that came with them should give this data or allow you to calculate it. The amplitude can also be measured using an oscilloscope. Set the SW601 switches according to the maximum amplitude using the chart below.

SW601 SWITCHES				
Pulse Amplitude (volts)	RTACH		LTACH	
	1	2	3	4
.25 - 2.0	Open	Closed	Closed	Open
1.0 - 50.0	Closed	Open	Open	Closed

- d) Determine the frequency of the LTACH pulse tach at maximum machine speed. Calculation is usually the best method. Look on the pulse tach data sheet for the number of pulses per revolution and multiply by the revolutions per second, considering any gear ratios that may be used.
- e) Determine the frequency of the RTACH pulse tach at maximum machine speed and at core diameter. Calculation is the best method. Take all gear ratios into account.
- f) Set the SW602 switches according to the frequencies in steps d) and e) above.

SW602 SWITCHES				
Frequency	RTACH		LTACH	
	1	2	3	4
180 Hz - 1.7 KHz	Closed	Closed	Closed	Closed
1.1 KHz - 40 KHz	Open	Closed	Closed	Open

Note: Opening switch 2 disables the RTACH output. Opening switch 3 disables the LTACH output.

- g) Set the LTACH span pot. Run the machine at maximum speed. (As an alternate method, run the machine at 50% of maximum speed. Set the output voltages at 50% of the values specified below)
- h) Measure the LTACH output voltage at test points TP601 (+) and TP603. Adjust the LTACH Span pot. (RT601) for 10.0 volts.
- i) Set the RTACH span pot. With the machine running at full speed, measure the RTACH output voltage at test points TP602 (+) and TP603. Adjust the RTACH Span pot. (RT602) for 10.0 volts AT THE CORE DIAMETER. As an alternate method, measure the roll diameter and adjust the RTACH Span pot. to a voltage equal to: $10 \times (\text{core diameter}) / (\text{roll diameter})$

Note: If you ran the machine at half speed, set the output voltages at 50% of the values above.

6.9 REMOTE TENSION AMPLIFIER (See Page 7 for description, Figure 16 for switches)

The three pin transducer cable connectors are removed, one hole is covered, and a two pin connector is installed in the other. A two conductor cable supplies the 0-10VDC tension signal from the remote device to the SteadyWeb controller. The meter in the controller is fed from the remote device signal, and it is calibrated by the ZERO and CAL pots. in the remote device. Switch SW102 must be set to accept the tension signal from either the local amplifier or the remote one.

- a) Set the SW102 switches as in the following table:

SW102 SWITCHES	
LOCAL	REMOTE
1 - Closed	1 - Open
2 - Open	2 - Closed
3 - NA	3 - NA
4 - NA	4 - NA

NA = Not Applicable

- b) The remote tension signal usually comes into the controller via the pre-wired cable connector on the bottom of the enclosure. If the connector is not used, make connections at the terminal strip on the Power board as shown in Figure 32.

TB203 (partial view shown)

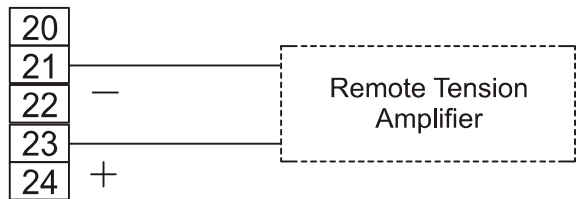

Figure 32 - REMOTE TENSION AMPLIFIER ELECTRICAL CONNECTIONS

6.10 TAPER ADJUSTMENT ON FRONT PANEL (See Page 7 for description)

No special calibration procedures are needed. This option is selectable by SW501 or SW801 located on the Taper option card.

6.11 TAPER TENSION (See Page 7 for description)

1. **Taper tension by Diameter Computer.** This requires a Taper/Diacalc card and either a DC Tachometer card or a Pulse Tachometer card. Calibrate the Tachometer card as explained above. The following procedure calibrates the Dia/calc card.

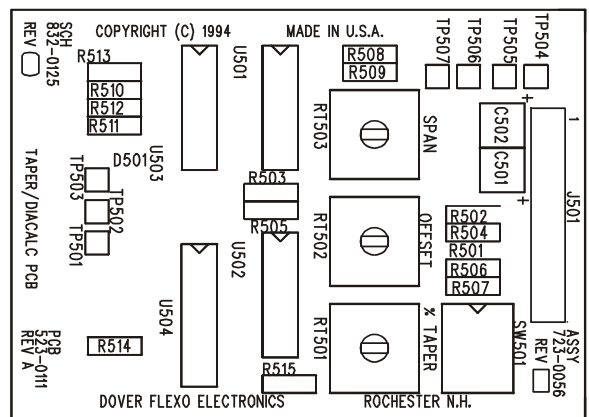

Figure 33 - TAPER DIA/CALC OPTION CARD

- a) Set the SW501 switches to select between the local taper adjustment pot., located on the Taper card, and an optional pot. located on the controller front panel.

SW501 SWITCHES				
	1	2	3	4
On Taper Card	NA	NA	Open	Closed
On Front Panel	NA	NA	Closed	Open

Note: Switches 1 and 2 are not used.

- b) Web the machine and run at any speed above 2% of maximum speed (the output of this card is off at 0 - 2%). Make the following measurements and adjustments:
- c) Set the OFFSET pot.(RT502) to 0, fully counterclockwise.
- d) At the core diameter, measure voltage between test points TP504 (+) and TP507. Adjust the SPAN pot.(RT503) for 10 volts DC.
- e) At the full roll diameter, measure the voltage between test points TP504 (+) and TP507. Adjust the OFFSET pot.(RT502) for 0 volts DC at the same speed as core.
- f) Repeat steps d) and e) as needed to ensure that tension begins to decrease at slightly above core diameter and continues to decrease until full roll diameter is reached.
- g) These settings should produce 0 VDC at core and +10 VDC at full roll as measured at test points TP503 (+) and TP507 when the TAPER pot.(TR501 or optional front panel pot.) is fully clockwise.
- h) Finally, adjust the TAPER pot.(RT501) to the amount of tension decrease desired. When the pot. is at 0, tension remains constant from core to full roll. When it is at 100, tension decreases linearly from the set level at core to 0 at full roll.

2. Taper by Rider Roll or external 10 Volt source. This requires a Taper/Rider card and either a rider roll operating a potentiometer or some other device capable of sensing rewind roll diameter and having a 0 to +10 Volt DC output. The rider pot. must have a resistance of at least 10,000 Ohms.

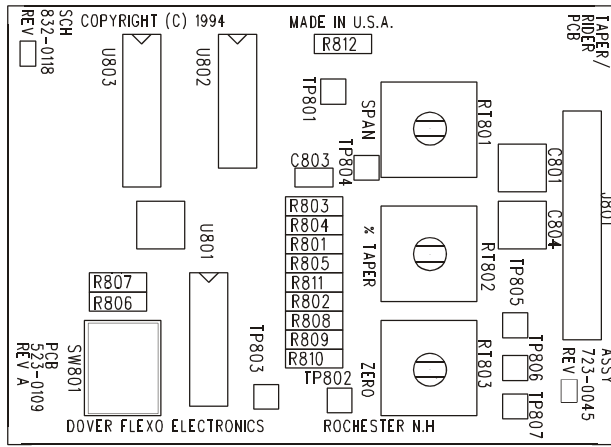

Figure 34 - TAPER RIDER OPTION CARD

a) Connect the rider roll pot. or voltage source as shown below.

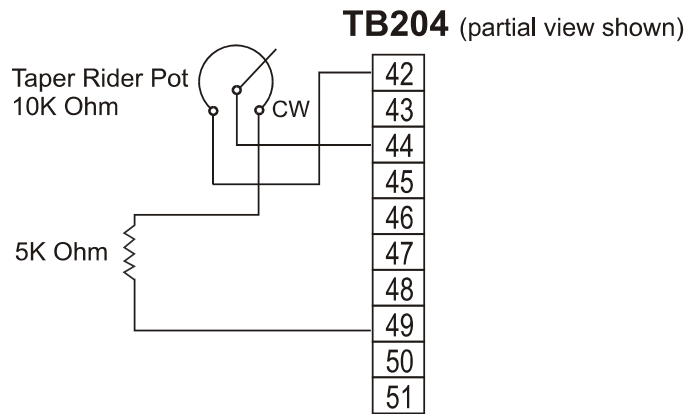

Figure 35 - RIDER ROLL CONNECTIONS

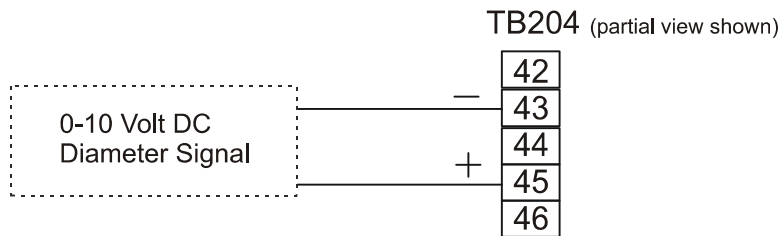

Figure 36 - 10 VOLT SOURCE CONNECTIONS

b) Set the SW801 switches to select between the local taper adjustment pot. and an optional pot. located on the controller front panel.

SW801 SWITCHES				
	1	2	3	4
On Taper Card	NA	NA	Open	Closed
On Front Panel	NA	NA	Closed	Open

Note: Switches 1 and 2 are not used.

- c) Cause the diameter sensor to output a voltage signal corresponding to the core diameter. Measure voltage between test points TP801 (+) and TP807. Adjust the SPAN pot. (RT801) for 10 volts DC.
- d) Cause the diameter sensor to output a signal corresponding to the full roll diameter. Measure the voltage between test points TP801 (+) and TP807. Adjust the ZERO pot.(RT803) for 0 volts DC.
- e) Recheck the voltage at core and adjust if necessary.
- f) These settings should produce 0 VDC at core and +10 VDC at full roll as measured at test points TP803 (+) and TP807 when the TAPER pot.(RT802 or optional front panel pot.) is fully clockwise.
- g) Finally, adjust the TAPER pot. to the amount of tension decrease desired. When the pot. is at 0, tension remains constant from core to full roll. When it is at 100, tension decreases linearly from the set level at core to 0 at full roll.

6.12 TENSION LIMIT SWITCH (See Page 7 for description)

This option requires a TLS option card which plugs into the Control board. The card operates the TLS relay (K201) which is located on the Power board, near the center.

- a) Set the SW104 switches on the Control board. Refer to Section 5.21, page 34

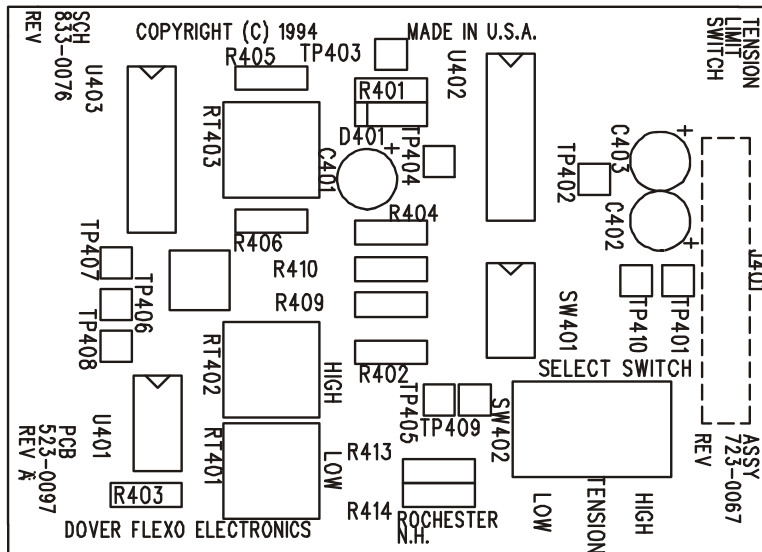

Figure 37 - TLS OPTION CARD

- b) Before starting the calibration procedure, decide if you want the TLS relay to turn off the controller output. Also decide if you want the relay to remain on (Latch) after tension goes back to normal. Latching requires installation of a Reset pushbutton on the front panel. Set the SW401 switches accordingly. Use the chart below.

SW401 SWITCH				
	1	2	3	4
Turn Off Tension	Closed	Open	NA	NA
Leave Tension On	Open	Open	NA	NA
Disable TLS	NA	Closed	NA	NA
Latch TLS Relay	NA	NA	NA	Closed
Do Not Latch TLS Relay	NA	NA	NA	Open

Note: Switch 3 is not used. NA = Not Applicable

- c) If the Reset button is required, install it in the front panel and connect it as shown below. The Reset button is only required if the Latch function is ON.

TB204 (partial view shown)

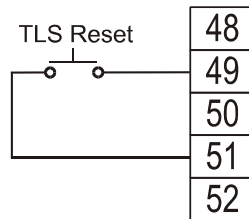

Used when LATCH feature is turned ON

Figure 38 - TLS RESET BUTTON CONNECTIONS

- d) Set the LOW trip point. Move the SELECT switch (SW402) to the LOW position. (If your TLS card has a 3-position rotary switch, turn it to the leftmost position.) If no Low trip point is desired, turn the LOW pot. (RT401) fully counter-clockwise. Otherwise, watch the tension meter on the front panel and turn the pot. until the meter reads the desired trip point.
- e) Set the HIGH trip point. Move the SELECT switch (SW402) to the HIGH position (rightmost position if switch is rotary). If no High trip point is desired, turn the HIGH pot. (RT402) fully clockwise. Otherwise, watch the tension meter on the front panel and turn the pot. until the meter reads the desired trip point.
- f) Move the SELECT switch (SW402) to the TEN position (center position if rotary). This is the normal operating position. The meter will now read actual tension.
- g) Set the time delay. This is the length of time the tension must be outside the Low or High trip points before the TLS relay will activate. The range is 0 to 5 seconds. Turn the RT403 pot. clockwise to increase the delay. Start with a delay of about 1 second. This will eliminate most nuisance tripping. Change it later if needed.
- h) Connect any necessary external circuits to the TLS relay contacts.

TB203 (partial view shown)

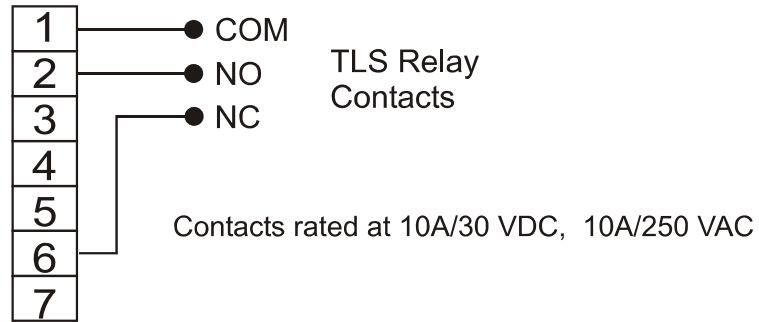

Figure 39 - TLS RELAY CONNECTIONS

7.0 INTRODUCTION

The procedures in this section apply to all versions of SteadyWeb controllers, used in all tension zones. Unlike most of the adjustments for standard features and options, tuning adjustments can not be preset at the factory for every application.

7.1 DESCRIPTION OF ADJUSTMENTS (see Figures 16, 41 Control Board)

There are three tuning adjustments; GAIN, STABILITY, and RESPONSE.

The GAIN pot. determines the sensitivity of the controller. A low setting will produce a small output change upon a tension error and a high setting will produce a large output change. Thus, if GAIN is set too low the running tension may be different from the set tension. If set too high, the controller may be unstable.

The STABILITY pots. (coarse and fine adjustments are provided) provide variable amounts of damping. If set too low, the controller may be unstable. If set too high, the controller may ignore some tension variations instead of correcting for them. The controller may also appear to be very slow to react.

The RESPONSE pot. adjusts the controller's reaction time when a tension variation occurs. If set too high, the controller may be unstable. Low settings are not a problem. This adjustment has relatively little affect compared to the STABILITY adjustment. It is normally used for fine tuning.

The adjustment pots. at the right side (labelled B) are only used with the DUAL CALIBRATION option. The adjustment procedure is identical to the one for the left side pots. (labelled A). If you have the Dual Calibration option, be sure to put the front panel switch in the "B" position before adjusting the "B" pots.

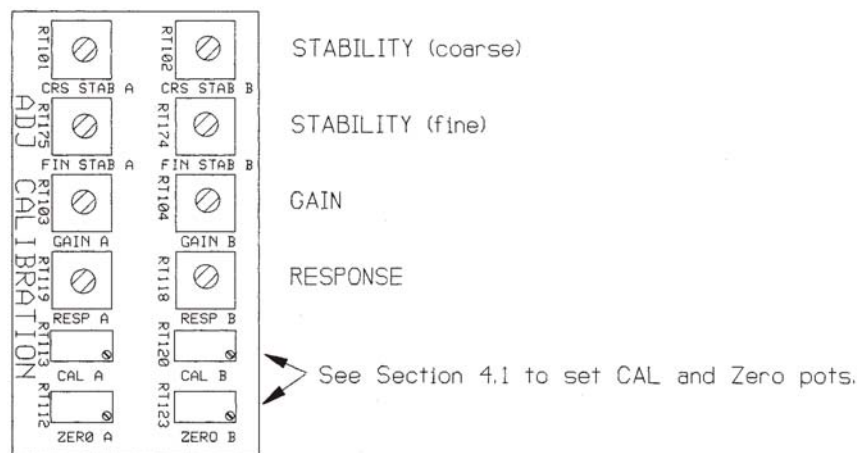

Figure 40 - TUNING POTS.

7.2 TUNING PROCEDURE

- a) Be sure the tension meter is calibrated properly (see Section 4). The controller may be impossible to tune if the meter is not calibrated.
- b) Set the pots. as shown below. Most systems will run stably with these initial settings. On the pots; 0% is at the fully counterclockwise position and 100% is fully clockwise.

GAIN ----- 10%
STAB (CRS) ----- 50%
STAB (FIN) ----- 50%
RESPONSE ----- 10%

If the controller is located in an intermediate tension zone, skip to Step 7.3 below.

- c) Turn the controller on and switch to the AUTO mode. Web-up the machine with a typical web material. Run the machine at normal operating speed. Use the AUTO pot. to set the tension at a normal value for the material.
- d) Adjust the STAB (CRS) pot. slowly up and down while watching the tension meter. Wait for a short time after each adjustment for tension to stabilize. Choose the setting where tension fluctuations are the least. Fine-tune using the STAB (FIN) pot.

Note: If the controller is controlling rewind tension, try to make these adjustments at or near core diameter. For an unwind controller, make it at or near full roll diameter. These are the points where the setting is most critical.

- e) Accelerate and decelerate the machine while watching the tension meter. If tension oscillates, readjust the STAB (CRS) pot. Then, adjust the RESPONSE pot. to minimize the time needed for tension to return to the set value.
- f) Run a full roll of material starting at the core (rewind) or full roll (unwind). Record the starting tension. At the end of the roll, record the ending tension. If it is lower or higher than the starting tension, GAIN is set too low. Increase the setting and repeat steps d), e) and f).

NOTE: It is usually not a good idea to use the GAIN pot. to achieve stability. Use the STAB pot. instead. The purpose of the GAIN pot. is to ensure that the actual web tension is the same as the set tension, regardless of roll diameter or machine speed. However, if GAIN is set higher than is necessary to achieve this, it may produce greater stability to reduce its setting.

7.3 TUNING THE SPEED FOLLOW FUNCTION

The following procedure applies to the Follow function only. This uses only the line speed signal. No nip roll speed signal is needed or desired.

- a) Be sure the DC Tach card (or Pulse Tach card, if used) has been properly calibrated. See Section 6.3 or 6.8.

- b) Be sure the SW101 switches on the Control board are correctly set. Switch 3 must be open and switch 4 must be closed.
- c) On the Control board, turn the TEN TRIM pot.(RT105) to 0. (fully counterclockwise)
- d) Remove the web and run the machine at normal speed. Using a hand-held tachometer, measure the surface speed of a driven roll running at machine speed. Then measure the surface speed of the driven nip roll that is controlled by the SteadyWeb. Adjust the LTACH Span pot. on the TACH card to match the nip roll speed to the machine speed.
- e) Set the TEN TRIM pot. to 20%.

Note: The TEN TRIM should not be set high. It could cause tension transients at start up and instability while running. A setting of 10 to 20% is usually ideal.

- f) Go back to Section 7.2, step c) to continue tuning.

SECTION 8

REPLACEMENT PARTS

Listed with Dover Part Numbers

8.0 STANDARD CIRCUIT BOARDS

Front board.	723-0023
Control board.	723-0012
Power board.	723-0001

8.1 OPTIONAL CIRCUIT CARDS

DC Tachometer Card.	723-0101
Dual Transducer Input Card.	723-0089
Interface Card.	723-0278 (For CC version only)
Pulse Tachometer Card.	723-0078
Taper-Dia/Calc Card.	723-0056
Taper-Rider Card.	723-0045
Tension Limit Switch Card.	723-0067

8.2 OPERATOR DEVICES

AUTO Set Pot.	101-0010
MANUAL Set Pot.	101-0010
Output meter, 0-100%	115-0000
Pushbutton, maintained	111-0005
Pushbutton, momentary	111-0006
Pushbutton cap, white	111-0004
Tension meter, analog.	721-0156 (specify scale)
Tension meter, digital.	723-0289 (optional)

8.3 OUTPUT MODULES

Vout board	723-0034 (High voltage output module for version 12V)
Pneumatic module	723-0821 (For version 12P only)
0-10 Volt Compensated module	104-0001 (For version 12D only)
Remote Pneumatic module	723-0957 (For version 12P with 2E option only)

8.4 FUSES

Power board -1A/250V	108-0002 (All versions of controller)
5A/250V	108-0003 (For version 12V only)
Vout card --- 5A/250V	108-0003 (For version 12V only)

8.5 RIBBON CABLES

7 Conductor	723-0835 (For version 12V only)
14 Conductor	131-0000 (For version 12V only)
34 Conductor	721-0833 (Control board to Front board)
60 Conductor	721-0829 (Power board to Control board)
34 Conductor (6')	721-0088 (H6 Configuration)

8.6 RELAYS

Power	105-0000 (on Power board)
Tension Limit Switch	105-0019 (option), (on Power board)
Vout card	105-0001 (For version 12V only)
Dual Trans. Input card	105-0020 (option)

8.7 MISCELLANEOUS

Air filter	119-0002 (For version 12P only)
Air pressure regulator	119-0004 (For version 12P only)
Enclosure cover	323-0126
Servo valve	119-0003 (For version 12P only)

Appendix A:

Location of Standard Adjustments

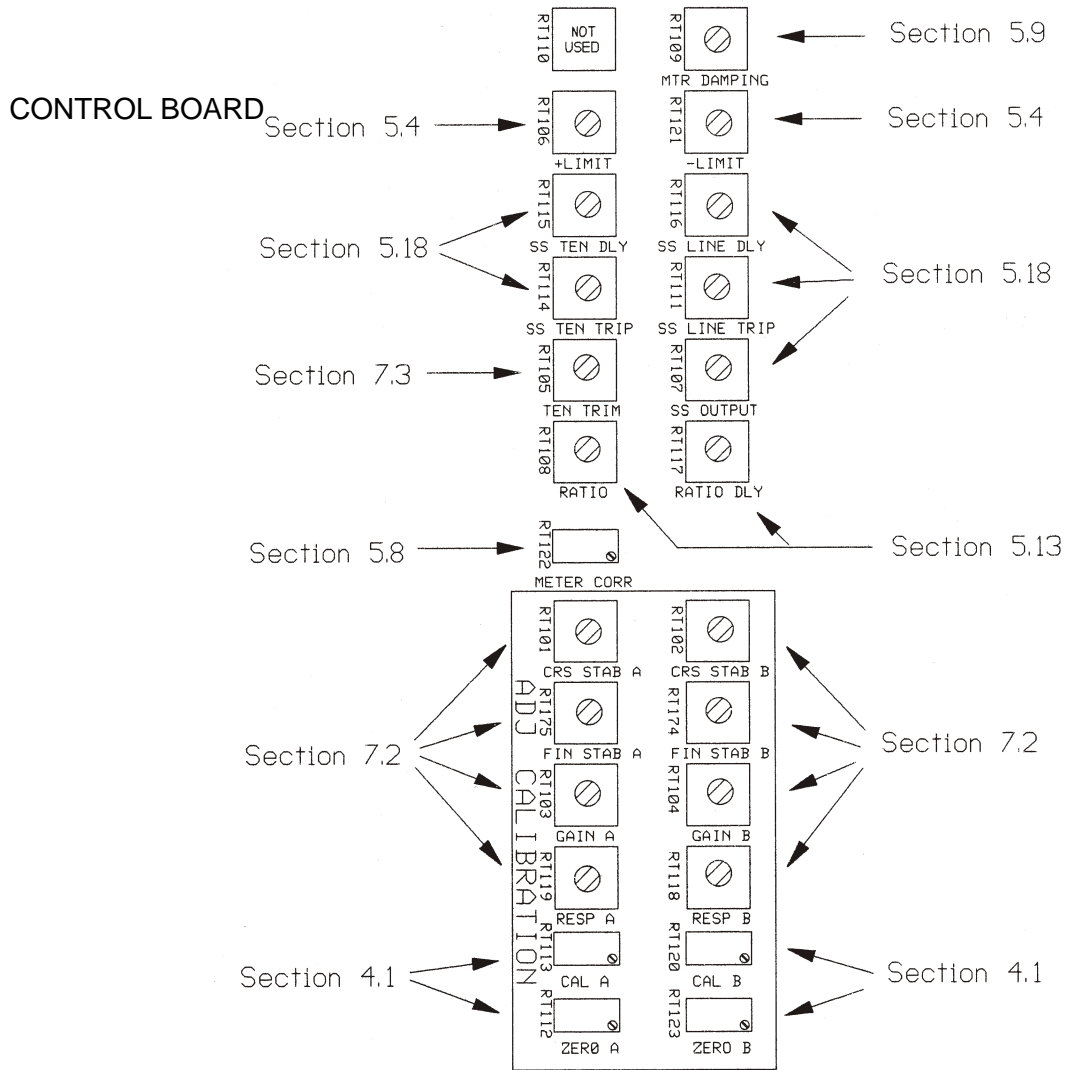

Figure 41 - STANDARD ADJUSTMENTS - CONTROL BOARD

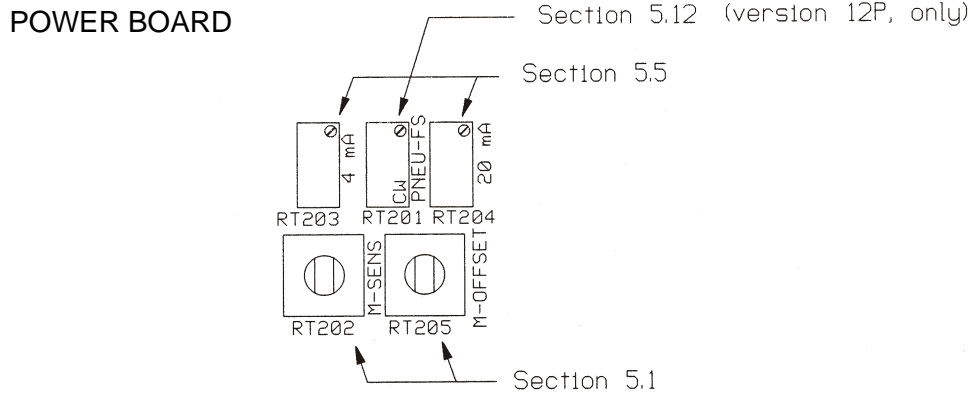

Figure 42 - STANDARD ADJUSTMENTS - POWER BOARD

The location of the setup instructions is listed after the switch number.

O = Switch is Open C = Switch is Closed

CONTROL BOARD *Fig. 16*

SW101 (pages 27, 33)

	<u>1</u>	<u>2</u>	<u>3</u>	<u>4</u>
Normal Output	O	C	-	-
Reverse Output	C	O	-	-
Speed Follow Off	-	-	-	O
Speed Follow On	-	-	-	C
Nip Roll Speed input Off	-	-	O	-
Nip Roll Speed input On	-	-	C	-

SW102 (pages 30, 43)

	<u>1</u>	<u>2</u>	<u>3</u>	<u>4</u>
Use Local tension signal	C	O	-	-
Use Remote tension signal	O	C	-	-
Use Local Auto Set pot.	-	-	C	O
Use Remote Auto Set pot.	-	-	O	C

SW103 (page 23)

	<u>1</u>	<u>2</u>	<u>3</u>	<u>4</u>
Control Voltage				
0 to +10	-	-	C	O
0 to -10	-	-	O	C
-10 to +10	-	-	O	O

SW104 (pages 31, 32, 33, 34)

	<u>1</u>	<u>2</u>	<u>3</u>	<u>4</u>
Soft Start Off	C	O	-	-
Soft Start On	O	O	-	-
TLS Card Absent	-	O	C	O
TLS Card Present	-	O	O	C

POWER BOARD *Fig. 17*

SW201 (pages 25, 28, 34)

	<u>1</u>	<u>2</u>	<u>3</u>	<u>4</u>	<u>5</u>	<u>6</u>	<u>7</u>	<u>8</u>
Full Output on E-Stop	-	-	-	-	-	-	O	-
Zero Output on E-Stop	-	-	-	-	-	-	C	-
Output Meter 0 at Left	-	-	-	-	O	O	-	-
Output Meter 0 at Center -	-	-	-	C	C	-	-	-
No TACH Card Present	O	O	O	O	-	-	-	-
Std. TACH Card Present O	C	O	C	-	-	-	-	-
Custom TACH Card Present	C	O	C	O	-	-	-	-

TENSION LIMIT SWITCH CARD (option) *Fig. 37*

SW401 (page 47)

	<u>1</u>	<u>2</u>	<u>3</u>	<u>4</u>
Turn Off Control Output	C	O	-	-
Leave Control Output On	O	O	-	-
Disable TLS	-	C	-	-
Latch ON	-	-	-	C
Latch OFF	-	-	-	O

V-OUT BOARD (High Voltage Output Module for Version 12V, only) *Fig. 20*

SW401 (page 26)

<u>POWER IN</u>	<u>OUTPUT (VDC)</u>	<u>1</u>	<u>2</u>	<u>3</u>	<u>4</u>
115 VAC	0 - 90	O	C	O	O
	0 - 45	O	C	O	C
	0 - 24	C	O	O	C
230 VAC	0 - 180	O	C	O	O
	0 - 90	O	C	O	C
	0 - 45	C	O	O	C
	0 - 24**	O	C	O	O

** This is a factory-installed option, only!

TAPER-DIA/CALC CARD (option) *Fig. 33*

SW501 (page 44)

	<u>1</u>	<u>2</u>	<u>3</u>	<u>4</u>
Use Taper Pot. on Card	-	-	O	C
Use Taper Pot. on Front Pnl	-	-	C	O

PULSE TACH CARD (option) *Fig. 30*

SW601 (page 41)

<u>Pulse Amplitude (Volts)</u>	<u>1</u>	<u>2</u>	<u>3</u>	<u>4</u>
Initial Settings	C	O	O	C
0.25 to 2.0	O	C	C	O
1.0 to 50.0	C	O	O	C

SW602 (page 42)

	<u>RTACH</u>		<u>LTACH</u>	
<u>Frequency (Hz)</u>	<u>1</u>	<u>2</u>	<u>3</u>	<u>4</u>
180 to 1700	C	C	C	C
1100 to 40,000	O	C	C	O

Open 2 to disable RTACH
Open 3 to disable LTACH

RTACH = Roll speed input
LTACH = Line or machine speed input

DC TACH CARD (option) *Fig. 26*

SW701 (page 37)

		<u>1</u>	<u>2</u>	<u>3</u>	<u>4</u>
LTACH	If 55 is +	-	-	O	C
	If 53 is +	-	-	C	O
RTACH	If 56 is +	O	C	-	-
	If 54 is +	C	O	-	-

Note: 53,54,55,56 are terminals on TB204 on Power Board.

SW702 and SW703 (pages 37, 38)

<u>Tach Voltage</u>	<u>1</u>	<u>2</u>	<u>3</u>	<u>4</u>
Initial Settings	O	O	O	C
3 to 4	C	O	O	O
4 to 16	O	C	O	O
16 to 64	O	O	C	O
64 to 250	O	O	O	C

TAPER-RIDER CARD (option) *Fig. 34*

SW801 (page 45)

	<u>1</u>	<u>2</u>	<u>3</u>	<u>4</u>
Use Taper Pot. on Card	-	-	O	C
Use Taper Pot. on Front Pnl	-	-	C	O

This section of the instruction manual is provided for those cases in which many DIP switches or potentiometer settings may have been changed and it is reasonable to assume that nothing is set correctly. In order to get the controller operating properly perform the set-up in the sequence given below. This is the sequence we use at Dover Flexo Electronics. For the sake of clarity, the actual set-up steps are not repeated here because they are located elsewhere in this book. Their locations are stated after the set-up step descriptions.

1. Turn Off the AC power to the controller.
2. Remove the cover. Lift the front panel to expose the circuit boards.
(Section 2.1)
3. Set the DIP switches on the Control board.
(Appendix B, Sections 5 and 6)
4. Set the power voltage selection switch on the Power board.
(Section 5.3)
5. Set the DIP switches on the Power board.
(Appendix B, Sections 5 and 6)
6. Set the transducer voltage selection switch on the Power board.
(Section 5.22)
7. Turn On the AC power to the controller and check the power supplies. Refer to Figure 17, the Power Board. LEDs LD208 and LD209 should be lighted. Push the Power switch on the front panel to apply power to the controller circuits. LEDs LD205 and LD206 should be lighted. These four LEDs indicate the proper operation of the +/-15 volt DC power supplies. At this point, LED LD207 (+5VDC) and either the LD211 (5 volt) or LD212 (10 volt) transducer power LED should also be lighted. Push the AUTO/MANUAL button on the front panel to verify operation of the AUTO and MAN LEDs on the front panel.
8. Calibrate the tension meter.
(Section 4)
9. Adjust the Meter Correlation pot.
(Section 5.8)
10. Calibrate the 4-20mA tension output.
(Section 5.5)
11. Select the control voltage.
(Section 5.4)
12. Set up the output module.
(Section 5.7 High Voltage output, Version 12V)
(Section 5.12 Pneumatic output, Version 12P)
(No additional setup required for 0-10V output, Version 12D)

13. Adjust the output meter.
(Section 5.11)
14. Check operation of Emergency Stop, if used.
(Section 5.6)
15. Set up Soft Start, if used. If Soft Start is speed-actuated, perform step 18 first.
(Section 5.18)
16. Check operation of Sample & Hold.
(Section 5.17)
17. Adjust the Ratio function, if used.
(Section 5.13)
18. Adjust the DC TACH or PULSE TACH card, if used.
(Section 6.3, DC Tach card)
(Section 6.8, PULSE Tach card)
19. Set up the TAPER card, if used.
(Section 6.11)
20. Set up the TLS (tension limit switch) card, if used.
(Section 6.12)
21. Tune for running stability.
(Section 7)

Appendix D:

Electrical Connections of Standard SteadyWeb

TB203 and TB204 are located on the Power Board (Figure 17)

(See Section 3.1 for electrical connections of CC configuration)

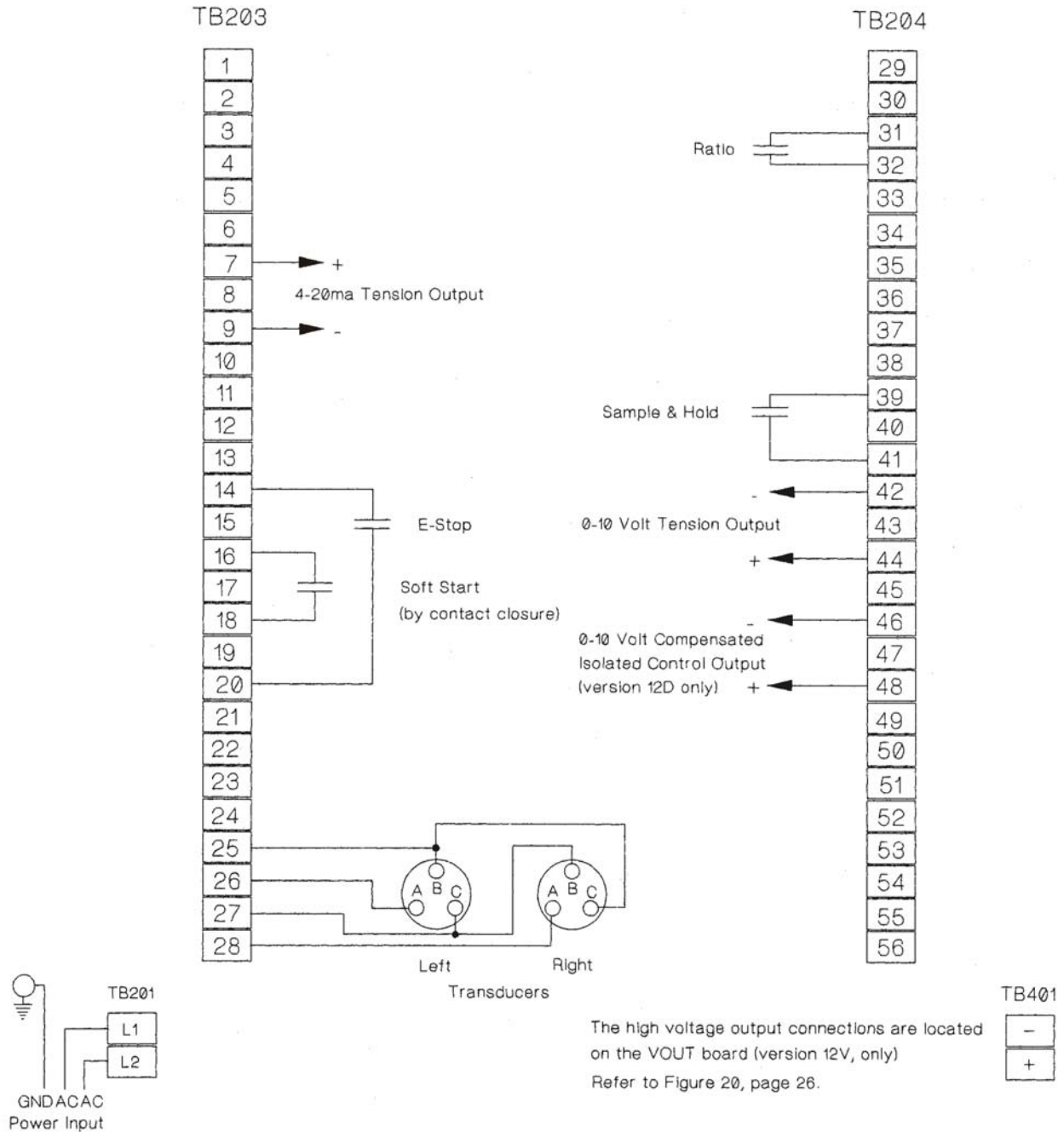
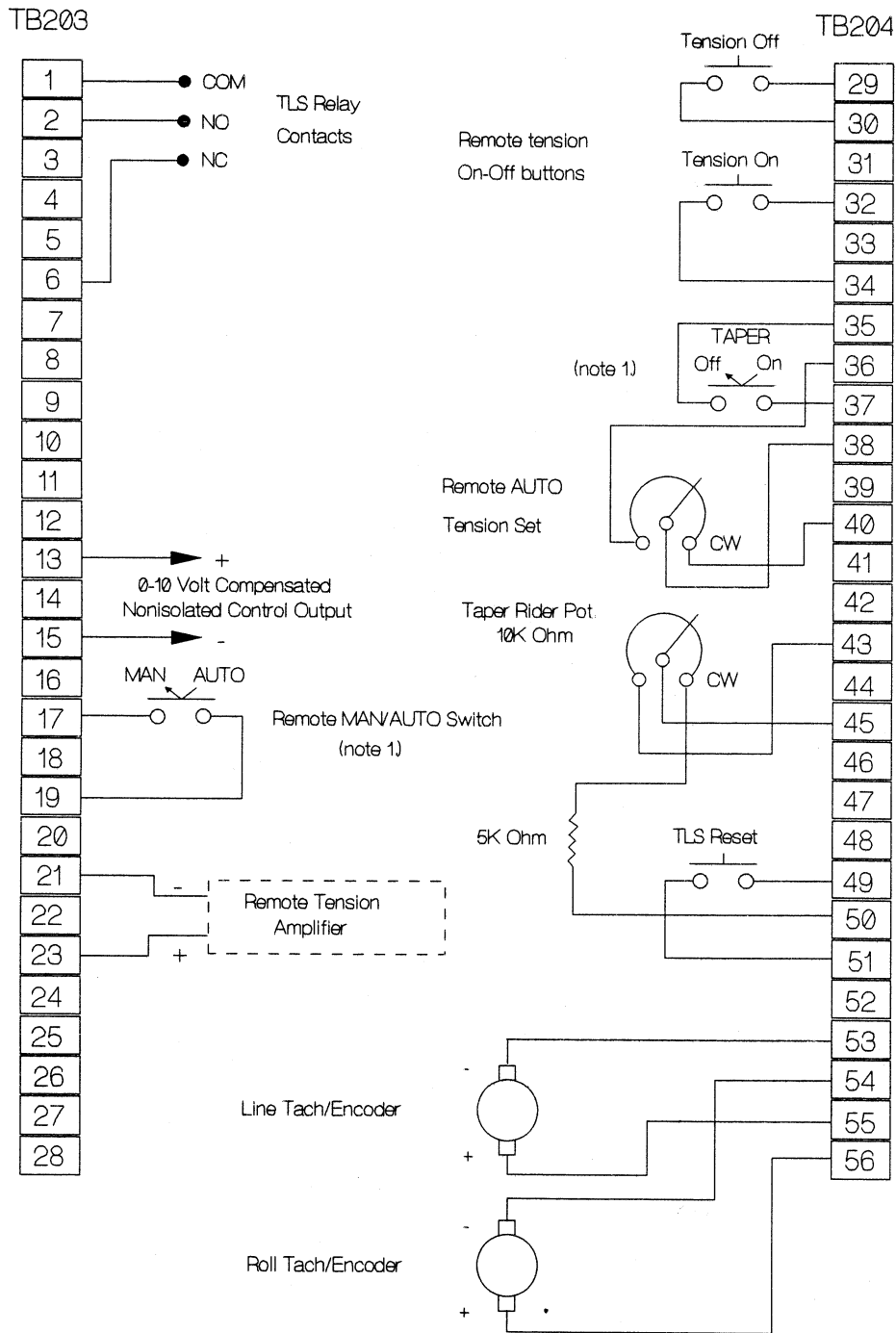

Figure 43 - STANDARD ELECTRICAL CONNECTIONS

Appendix E:

Electrical Connections of Options for Standard SteadyWeb Unit

TB203 and TB204 are located on the Power Board (Figure 17).
 (See Section 3.1 for electrical connections of CC configuration)



NOTE: 1. Must disconnect the front panel device of the same name.

Figure 44 - OPTIONAL ELECTRICAL CONNECTIONS

Appendix F: Transducer Electrical Connections

MODELS C, RS, AND UPB TRANSDUCERS

THE TENSION (T) AND COMPRESSION STRAIN GAGES ARE CONNECTED IN A BRIDGE CONFIGURATION. AS THE BEAMS BEND SLIGHTLY UNDER WEB TENSION, THE GAGE RESISTANCES CHANGE PRODUCING AN OUTPUT SIGNAL WHICH IS DIRECTLY PROPORTIONAL TO THE WEB TENSION.

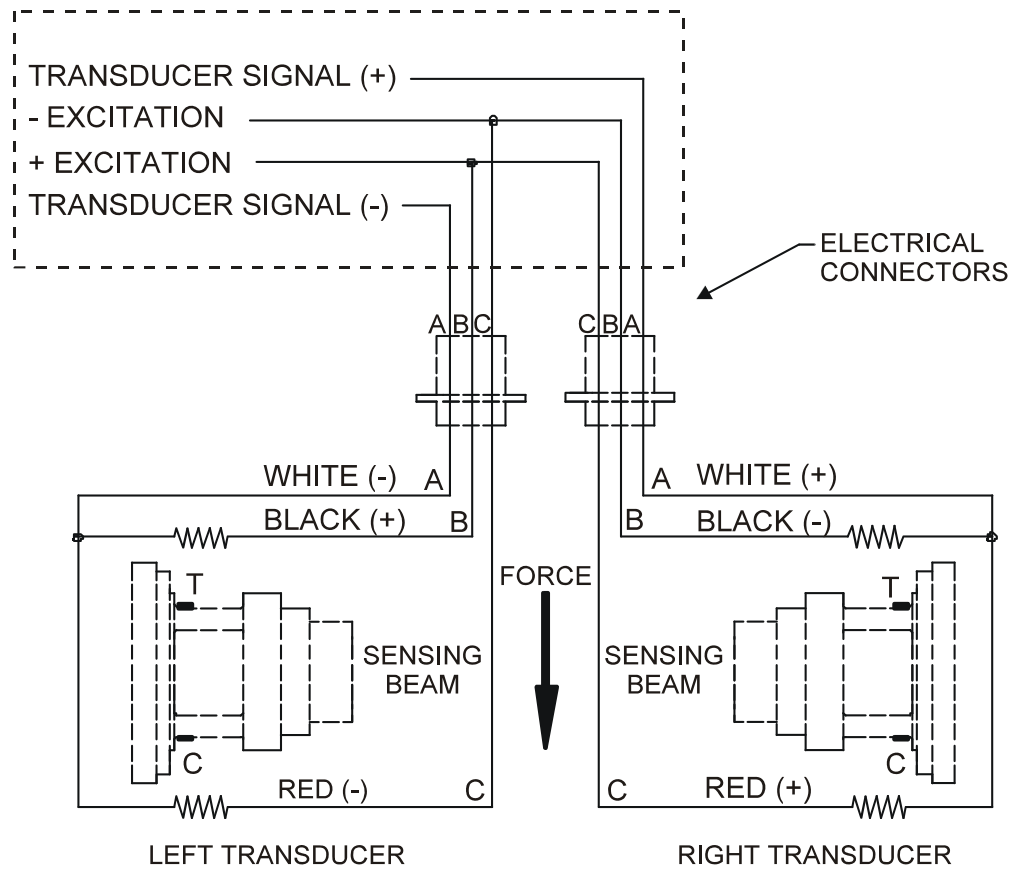

Figure 45 - MODELS C, RS, & UPB TRANSDUCER WIRING

RIBBON FILAMENT (RFA) & VNW TRANSDUCERS

THE TENSION (T) AND COMPRESSION (C) STRAIN GAGES ARE CONNECTED IN A BRIDGE CONFIGURATION. AS THE BEAMS BEND SLIGHTLY UNDER WEB TENSION, THE GAGE RESISTANCES CHANGE PRODUCING AN OUTPUT SIGNAL WHICH IS DIRECTLY PROPORTIONAL TO THE WEB TENSION.

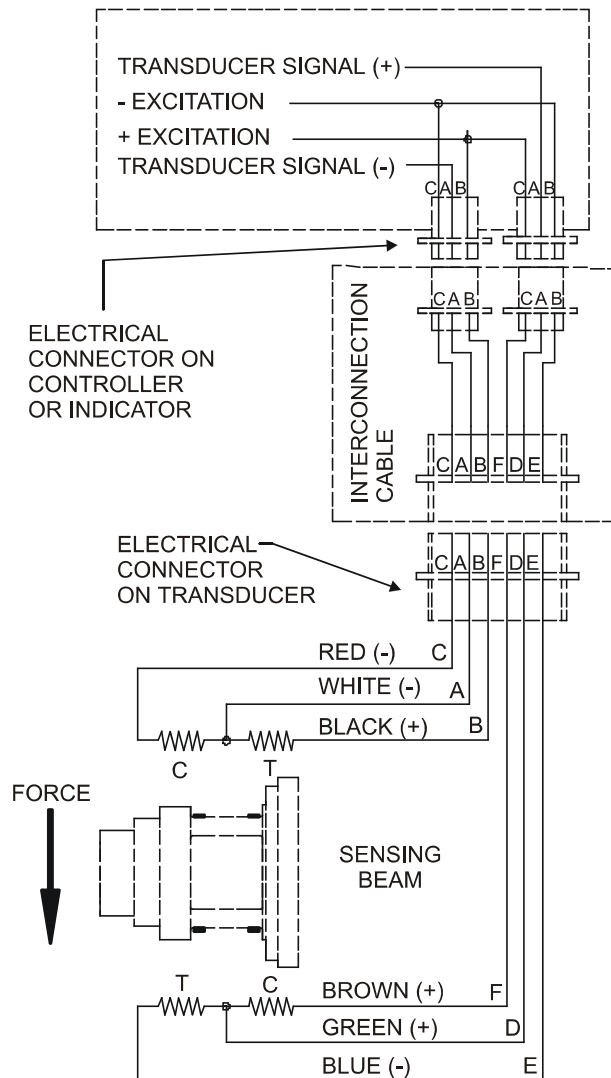

Figure 46 - MODEL RFA & VNW TRANSDUCER WIRING

TENSION ROLL (TR) AND NARROW WEB (NWI) TRANSDUCERS

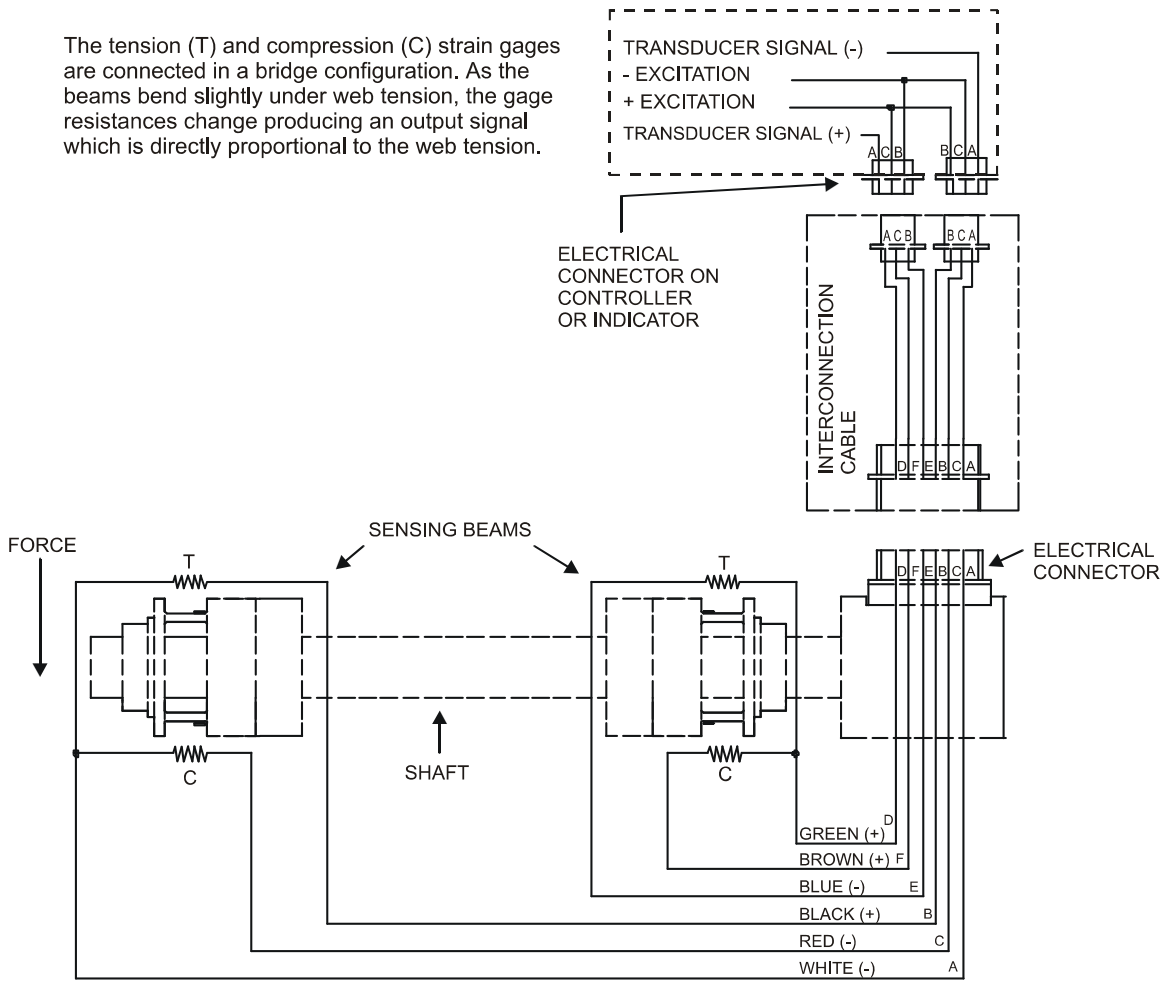
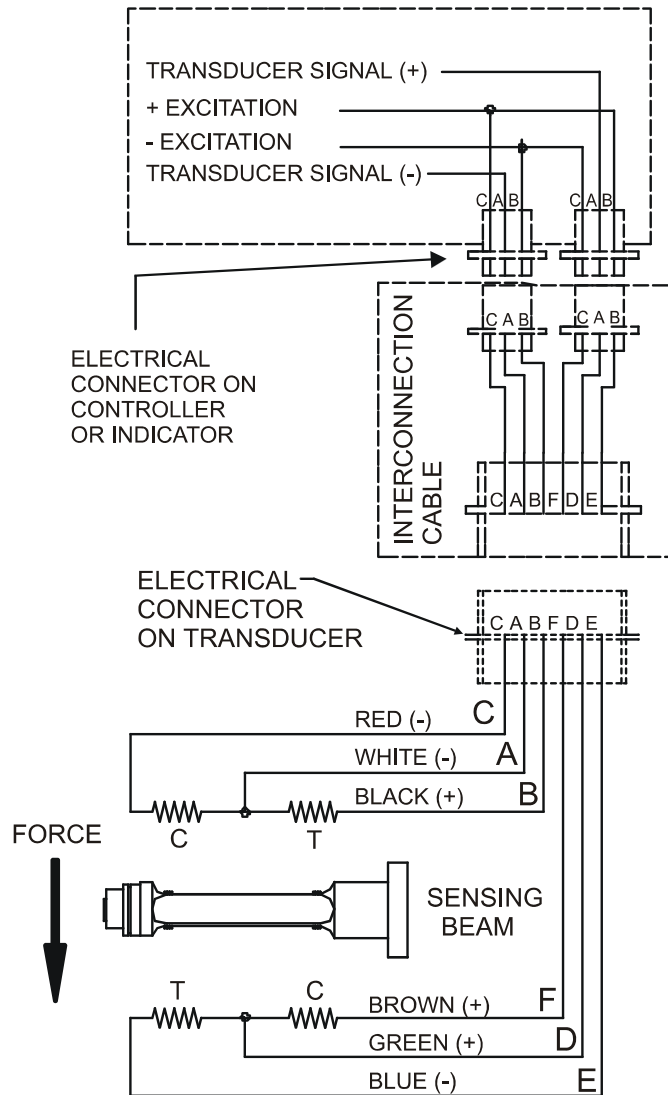

Figure 47 - MODELS TR & NWI TRANSDUCER WIRING

LOW TENSION (LT) TRANSDUCERS



Note: XR Option must be used with LT Transducers

Figure 48 - MODEL LT TRANSDUCER WIRING

Appendix G: Typical Tensions for Various Materials

TYPICAL TENSIONS FOR WEB MATERIALS

ACETATE	0.5 lb. per mil per inch of width		
FOIL	Aluminum	0.5 lb. per mil per inch of width	
	Copper	0.5 lb. "	
CELLOPHANE	0.75 lb. per mil per inch of width		
NYLON	0.25 lb. per mil per inch of width		
PAPER 15 lb *	0.4 lb. per inch of width		
	20 lb	0.5 lb. "	
	30 lb	0.75 lb. "	
	40 lb	1.25 lb. "	
	60 lb	2.0 lb. "	
	80 lb	3.0 lb. "	
	100 lb	4.0 lb. "	
* based on 3000 sq. ft. ream			
PAPERBOARD 8pt	3.0 lb. per inch of width		
	12pt	4.0 lb. "	
	15pt	4.5 lb. "	
	20pt	5.5 lb. "	
	25pt	6.5 lb. "	
	30pt	8.0 lb. "	
POLYETHYLENE	0.12 lb. per mil per inch of width		
POLYESTER (Mylar)	0.75 lb. per mil per inch of width		
POLYPROPYLENE	0.25 lb. per mil per inch of width		
POLYSTYRENE	1.0 lb. per mil per inch of width		
RUBBER	<u>GAUGE</u>	<u>AT 25% STRETCH</u>	<u>AT 50% STRETCH</u>
	10 mil	1.75	3.68
	12 mil	1.10	2.03
	16.5 mil	4.09	8.17
	26 mil	2.47	4.97
SARAN	0.15 lb per mil per inch of width		
STEEL	<u>GAUGE - INS</u>	<u>UNWIND-PSI</u>	<u>REWIND-PSI</u>
	.001 -.005	1000	4000
	.006 -.025	850	3500
	.026 -.040	750	3000
	.041 -.055	650	2600
	.058 -.070	550	2200
	.071 -.090	450	1800
	.091 -.120	450	1400
	.121 -.140	400	1200
	.141 -.165	400	1000
	.166 -.200	400	900
	.201 -.275	400	800
	.276 -.380	300	700
VINYL	0.05 lb. per mil per inch of width		

*** For laminated webs, sum the tension for the individual webs and add 0.1 lb per inch of width.

There are no adjustments or switches on this board. It is shown here for illustration purposes, only.

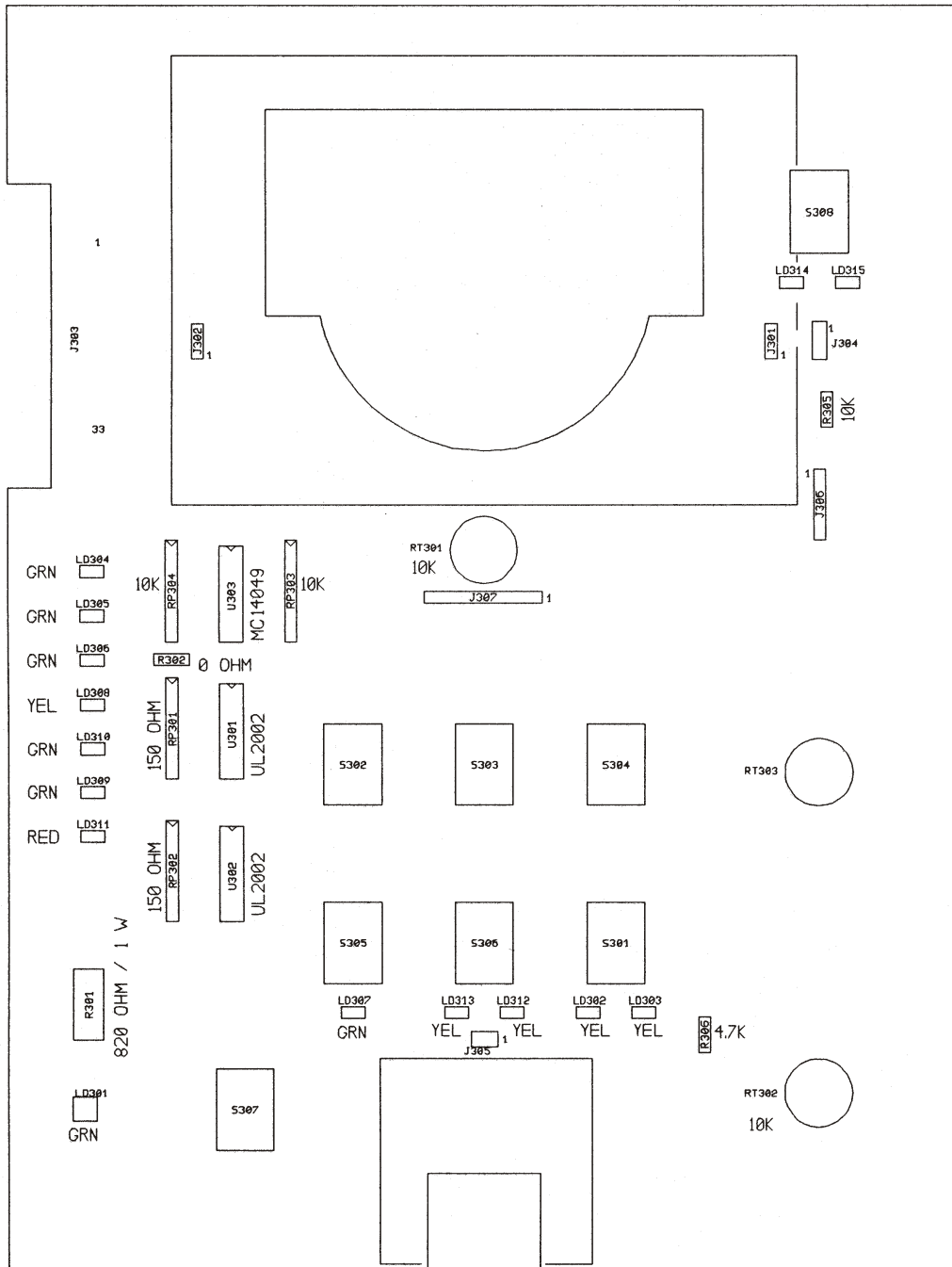

Figure 49 - FRONT BOARD

1. Most problems are caused by incorrect installation and misapplication of the equipment. So it is very important to be sure these factors are correct before making any changes to potentiometer and switch settings.

If you would like assistance evaluating your installation, please call Technical service at (603) 332-6150 (Fax: (603) 332-3758). We have experienced technicians whose responsibility it is to make sure you are satisfied with your DFE equipment. They will be pleased to help.

2. The most common source of improper operation of tension equipment is incorrect installation of the tension transducers or using transducers of the wrong load rating. Refer to your transducer instruction manual and check the sizing and installation procedures to verify the installation. NOTE: Avoiding pre-loading is very important for the "C" and "UPB" type transducers.
3. Verify the electrical connections to the SteadyWeb controller. Refer to Appendices D and E. Also Section 2 or 3.
4. Proper calibration of the tension meter is very important to the operation of the controller. Be sure the calibration is correct. Refer to Section 4. Improper calibration may cause unstable operation.
5. Verify the setting of the "meter correlation" pot. The setting is not critical, however if it is grossly misadjusted, the tension set pot on the front panel may not be able to turn tension on or to turn it off completely. Refer to Section 5.8
6. If your controller has a pneumatic output (SteadyWeb Version 12P), check the following factors:
 - A. The output pressure should not fall below 5 psi at core diameter. If it does, the controller may be unstable. This is caused by the compressibility of air which creates a time delay when the controller calls for a change of output pressure. At low pressures, the delay becomes long.
 - B. The air connection between the controller and the brake or clutch should be 1/4 inch O.D. tubing, no more than 25ft. long. Larger or longer tubing creates excessive volume which causes a time delay when output pressure changes. This can cause instability. If greater distance is unavoidable, you may want to use the remote pneumatic module option to install the servo valve near the brake or clutch. Use of a volume booster is an alternative. Call Technical Service at (603) 332-6150 for details.
7. If the above steps are not successful, perform the basic set-up sequence in Appendix C. If you get unexpected results in any step, call Technical Service at (603) 332-6150 for assistance.

TERMS AND CONDITIONS OF SALE AND SHIPMENT

1. THE COMPANY

Dover Flexo Electronics, Inc. is hereinafter referred to as the Company.

2. CONFLICTING OR MODIFYING TERMS

No modification of, additions to or conflicting provisions to these terms and conditions of sale and shipment, whether oral or written, incorporated into Buyer's order or other communications are binding upon the Company unless specifically agreed to by the Company in writing and signed by an officer of the Company. Failure of the Company to object to such additions, conflicts or modifications shall not be construed as a waiver of these terms and conditions nor an acceptance of any such provisions.

3. GOVERNING LAW

This contract shall be governed by and construed according to the laws of the state of New Hampshire, U.S.A. The parties agree that any and all legal proceedings pursuant to this contract shall take place under the jurisdiction of the courts of the State of New Hampshire in the judicial district of Strafford County.

4. PENALTY CLAUSES

Penalty clauses of any kind contained in orders, agreements or any other type of communication are not binding on the Company unless agreed to by an officer of the Company in writing.

5. WARRANTY

Dover Flexo Electronics, Inc. warrants, to the original Buyer, its' products to be free of defects in material and workmanship for five years from date of original shipment. Repairs on products are warranted for 90 days from date of shipment. During the warranty period the Company will repair or replace defective products free of charge if such products are returned with all shipping charges prepaid and if, upon examination, the product is shown to be defective. This warranty shall not apply to products damaged by abuse, neglect, accident, modification, alteration or mis-use. Normal wear is not warranted. All repairs and replacements under the provisions of this warranty shall be made at Dover Flexo Electronics or at an authorized repair facility. The Company shall not be liable for expenses incurred to repair or replace defective products at any other location or by unauthorized persons or agents. This warranty contains all of the obligations and warranties of the Company. There are no other warranties, either expressed or implied. No warranty is given regarding merchantability or suitability for any particular purpose. The Company shall not be liable in either equity or law for consequential damages, losses or expenses incurred by use of or inability to use its' products or for claims arising from same. No warranty is given for products of other manufacturers even though the Company may provide these products with its' own or by themselves. The provisions of this warranty can not be changed in any way by any agent or employee of the Company. Notice of defects must be received within the warranty period or the warranty is void. The warranty is void if the serial number tag is missing or not readable.

6. PAYMENTS

Standard terms of credit are net 30 days from date of shipment, providing satisfactory credit is established with the Company. Amounts past due are subject to a service charge of 1.5% per month or portion thereof or 18% per annum. The Company reserves the right to submit any unpaid late invoices to a third party for collection and Buyer shall pay all reasonable costs of such collection in addition to the invoice amount. All quoted prices and payments shall be in U.S. Dollars.

If the Company judges that the financial condition or payment practices of the Buyer does not justify shipment under the standard terms or the terms originally specified, the Company may require full or partial payment in advance or upon delivery. The Company reserves the right to make collection on any terms approved in writing by the Company's Finance Department. Each shipment shall be considered a separate and independent transaction and payment therefore shall be made accordingly. If the work covered by the purchase order is delayed by the Buyer, upon demand by Company

payments shall be made on the purchase price based upon percentage of completion.

7. TAXES

Any tax, duty, custom, fee or any other charge of any nature whatsoever imposed by any governmental authority on or measured by any transaction between the Company and the Buyer shall be paid by the Buyer in addition to the prices quoted or invoiced.

8. RETURNS

Written authorization must be obtained from the Company's factory before returning any material for which the original Buyer expects credit, exchange, or repairs under the Warranty. Returned material (except exchanges or repairs under the Warranty) shall be subject to a minimum re-stocking charge of 15%. Non-standard material or other material provided specially to the Buyer's specification shall not be returnable for any reason. All material returned, for whatever reason, shall be sent with all freight charges prepaid by the Buyer.

9. SHIPPING METHOD AND CHARGES

All prices quoted are EXW the Company's factory. The Company shall select the freight carrier, method and routing. Shipping charges are prepaid and added to the invoice of Buyers with approved credit, however the Company reserves the right to ship freight-collect if it prefers. Shipping charges will include a charge for packaging. Company will pay standard ground freight charges for items being returned to Buyer which are repaired or replaced under the Warranty.

10. CANCELLATION, CHANGES, RESCHEDULING

Buyer shall reimburse Company for costs incurred for any item on order with the Company which is cancelled by the Buyer. Costs shall be determined by common and accepted accounting practices.

A one-time hold on any item ordered from the Company shall be allowed for a maximum of 30 days. After 30 days, or upon notice of a second hold, Company shall have the right to cancel the order and issue the appropriate cancellation charges which shall be paid by Buyer. Items held for the Buyer shall be at the risk and expense of the Buyer unless otherwise agreed upon in writing. Company reserves the right to dispose of cancelled material as it sees fit without any obligation to Buyer.

If Buyer makes, or causes to make, any change to an order the Company reserves the right to change the price accordingly.

11. PRICES

Prices published in price lists, catalogs or elsewhere are subject to change without notice and without obligation. Written quoted prices are valid for thirty days only.

12. EXPORT SHIPMENTS

Payment for shipments to countries other than the U.S.A. and Canada or to authorized distributors shall be secured by cash in advance or an irrevocable credit instrument approved by an officer of the Company. An additional charge will apply to any letter of credit. There will also be an extra charge for packaging and documentation.

13. CONDITION OF EQUIPMENT

Buyer shall keep products in good repair and shall be responsible for same until the full purchase price has been paid.

14. OWNERSHIP

Products sold are to remain the property of the Company until full payment of the purchase price is made.

INDEX

0-10 Volt Isolated Compensated Output	1, 2, 3, 23
0-10 Volt Nonisolated Compensated Output	12, 23
0-10 Volt Tension Output	4
12D Model	1
12P Model	1
12V Model	1
220 Volt Power	3,6,35
4-20mA Tension Output	4, 24
AC Power Connections	11, 17,22
Adjustments (also see specific options)	26, 49, 54, 21, 22
Automatic Control Mode	4
Cal	18, 21, 54
Calibration, Tension Meter	18-19
Chassis Configuration	6, 15-17
Control Board	2, 21
Control Voltage Selection	23-24
Cover, removal of	10
DC Tachometer Card	6, 36-38
DIP Switch Settings	55-57
Digital Meter	6, 38-40
Dimensions	9, 10,14,15
Dual Calibration	6, 40
Dual Transducer Input	6, 40
Electrical Connections, CC	16-17
standard	11, 60
optional	12, 61
transducer	62-64
Emergency Stop	4, 25
Extended Range	6, 40
Front Board	2, 66
Front Panel	2, 8
Fuses, replacement	52
Gain	21, 49-50, 54
H6 (Remote Operator Device)	6
High Voltage Output Module	2, 26-27
Installation	
standard unit	9-12
H6	13-14
CC	15-17
Manual Control Mode	4
Meter,	
correlation Pot.	4, 27
damping	4, 27
mechanical Zero	18
non-standard meter scale	6
Metric Air Tubing	6
Mounting Screws	10, 15
Operator Devices	8
replacement	52
Options	6-7
Option Codes	6-7
Output Direction	4
Output Meter	4
Output Module	1
replacements	52
Output,	
24 volt	3, 6, 26, 36
45 volt	3, 6, 26, 36
90 volt	3, 26
180 volt	3, 26
normal	4, 7
reverse	4, 7
Pneumatic Output Module	2, 28, 52
Power Board	2, 22
Power Voltage Selection	4, 23
Pulse Tachometer Card	6, 41
Ratio	4, 29
Relays, replacement	53
Remote Operator Devices (H6)	7, 13-14
Remote Pneumatic Module	7, 9, 52
Remote Tension Amplifier	7, 12, 30, 17
set-up & adjustment	42
Remote Tension On/Off	5, 30
Remote Tension Set	5, 30
Replacement Parts	52-53
fuses	52
miscellaneous	53
operator devices	52
optional circuit cards	52
output modules	52
relays	53
std. circuit cards	52
ribbon cables	52
Response	21, 49-50, 54
Ribbon Cables, replacement	52
Sample & Hold	5, 31
Set-up, basic	58
Soft Start	5, 31
Specifications	3
Speed Follow	5,33
Speed Match	5
Stability	21, 49-50, 54
Standard Features	4-5
Status Lights	5, 8
Switch Settings	55-57

..... continued next page

INDEX continued.....

TLS Card installed?	34
Tachometer Card installed?	34
Taper Adjustment, front panel	7, 8, 43
Taper Tension	7, 43-46
Tension Display	5
Tension Limit Switch	7, 46
Tension Meter	3, 5, 8, 18, 27, 52
standard scales	3
digital	6, 38-40, 52
Tension Output, 0-10V	4, 11
4-20mA	4, 11
Tension Output, 0-20m	24
Tension Zones	20
Terms & Conditions	69
Transducer Voltage Selection	5, 34-35
Tuning for stability	
adjustments	49
procedure	48-50
speed follow	50-54
Typical Tensions	66
V-OUT Card	1, 2, 26
Version of Controller	1
Zero	18, 21, 54



217 PICKERING ROAD
ROCHESTER, NEW HAMPSHIRE 03867-4630 U.S.A
TEL: 603-332-6150
FAX: 603-332-3758
E-mail: info@dfec.com Internet: www.dfec.com

CANADA

MEXICO

UNITED KINGDOM

EUROPE

TAIWAN

KOREA

AUSTRALIA

COLOMBIA

INDIA

SOUTH AFRICA

CHINA