

ROLL SHELL TENSION TRANSDUCER

Dover's Roll Shell Transducer (RS) is a special variation on the Model C transducer that, when used in pairs, attaches into each end of an idler roll shell. Without other shaft or external bearing hardware, this transducer provides for a quick and easy tension-sensing roll installation at an attractive total hardware cost.

The Roll Shell Transducer uses a special connecting collar to facilitate smooth insertion of the transducers into the roll and achieve a tight, solid fit between the two. The collar's expanding collet design allows a perfect fit into the roll bores. By eliminating potential gaps at the transducer/roll

interface the expanding collet prevents wear between the transducer and roll. It also prevents run out, and looseness.

The RS allows for up to 1/4" (0.64 cm) of axial thermal expansion for idler rolls which experience large temperature swings. In order to permit this expansion, the RS units are provided in matched pairs of one floating unit and one anchored unit. The expansion and contraction takes place at one end only so the roll does not shift axially.

FEATURES

- **Grease fitting** for re-lubrication without disassembly or removal from the machine;
- **Integral overload protection** against tension transients;
- **Thermal expansion compensation** for up to 1/4" (1/2" optional).
- **Corrosion resistant construction** of aluminum, bronze and stainless steel parts;
- **Compensation for up to 2°** angular mis-alignment of the coupling.
- **Three mounting styles:** S, FL, PB

BENEFITS

- **Cost savings.** No shaft and no external bearings. You can make your own roll or have DFE make it.
- **Roll strength.** No shaft to flex. The roll provides high resistance to bending and achieves a high resonant frequency.
- **Suitability for hot webs.** Large axial expansion capability to accommodate hot rolls.
- **Low runout.**

OPTIONS

- **Drill and Tap (D&T).** Drill and tap ends of shaft.
- **Environmental Connector (EC).** Seals with mating cable electrical connector to protect against contact oxidation; especially useful in corrosive environments.
- **Extended Range (XR).** Extended Range produces twice the output signal for a given load rating. Used to provide sufficient signal at very low tensions. Electronics must have XRE option.
- **Labyrinth Seal (LS).** A non-contact seal used for minimal drag for very low break-away torque.
- **Metric Mounting Stud (MMS).** Metric mounting screw for S type transducers.

ORDERING INFORMATION

You may order from description or by specifying the code below by matching each labeled digit with one of the choices given. **Example: RS2S-50-F-6-MMS,XR**

RS 1 - S - 25 - F - 6 - OPTIONS (Separated by commas)

SIZE	MOUNTING STYLE	LOAD RATING	COUPLING	CONNECTOR POSITION	OPTIONS
1 2	S = Screw/bolt FL = Flange PB = Pillow Block	10 lbs. ¹ 25 lbs. 50 lbs. 100 lbs. 150 lbs. ¹ 200 lbs. ² 400 lbs. ² 800 lbs. ²	F = Floating A = Anchored	6:00 (Standard) 1:30 3:00 4:30 7:30 9:00 10:30 12:00 R (Rear-PB only)	D+T = Drill and Tapped EC = Environmental Connector LS = Labyrinth Seal MMS = Metric Mounting Stud XR = Extended Range ³ Z = Special

NOTES: 1. Size 1 only. 2. Size 2 only. 3. Electronics must have XRE option.

SPECIFICATIONS

ELECTRICAL

Excitation: 5 Vdc, regulated (10Vdc with XR)
Output: 250mVdc, nominal, at 5V excitation
 (500mV at 10V excitation with XR)
Strain Gage Resistance: 100 ohms, nominal
Non-Repeatability: ±1/4% Full Span (FS)
Combined Non-Linearity and Hysteresis: ±1/2% (FS)
Temperature Range: -10°F to 200°F (-23°C to 93°C)
Temperature Coefficient: 0.02% FS per °F, typical
 (0.036% FS per °C)

Mating Electrical Connector:
 Amphenol MS3106A-10SL-3S

Connector Pin Assignment:

A = transducer output
 B = + 5V
 C = - 5V

MECHANICAL

Overload Capacity: Size 0,1 = 1200 lbs. (5338 N),
 Size 2 = 2500 lbs. (11,121 N),
Deflection of Sensor Beam: 0.005 in. maximum
 (0.127 mm)

Misalignment Capacity: (degrees) 2

Materials: 6061, 7075-T6 Aluminum;
 303, 304 Stainless Steel

Connector Position (standard):

Screw (S) , Flange (FL) mount = 6 o'clock
 Pillow Block (PB) mount = 12 o'clock

Load Ratings:

Size 1: 10, 25, 50, 100, 150 lbs.
 (44, 111, 222, 445, 667 N)
 Size 2: 25, 50, 100, 200, 400, 800 lbs.
 (111, 222, 445, 890, 1779, 3559 N)

Weight: Size 1: 3.5 lbs (15.6 N), Size 2: 5 lbs. (22.2 N)

Unit Coupling Weight:: Size 1: 2 lbs. (8.9 N)
 Size 2: 3.5 lbs. (15.6 N)

ORDERING INFORMATION

The correct transducer load rating for your application is determined by maximum web tension, wrap angle, and idler roll weight. Choose the appropriate wrap configuration from the diagrams below. Then compute the Net Force using the formula below the diagram. (*The direction of the tension force determines which diagram and formula to use*).

In some cases, the load rating may be **less** than the computed Net Force. This is acceptable because the Net Force formula contains an oversizing factor of 2, which means that the actual force exerted on the transducer will not exceed its rating.

Sometimes, a transducer roll is so heavy that its weight uses up most of the operating range of the transducers.

When this happens, it may not be possible to adjust the tension indicating meter to read zero when tension is zero because the adjustment range of the electronic circuit has been exceeded. To find out if the roll is too heavy, compare the load rating with the effective weight of the roll as follows: The effective roll weight is the "WCOS(A)" term in the formula. If WCOS(A) is more than 95% of the load rating chosen, the tension meter will probably not be adjustable to zero. If this is the case, one or more of the following changes must be made to reduce WCOS(A) to less than 95% of the load rating:

1. Reduce the roll shell weight
2. Increase angle (A)
3. Use the next higher load rating. (This is the least desirable choice because it reduces transducer signal)

WRAP 1

Tension Force F_T , **above** horizontal

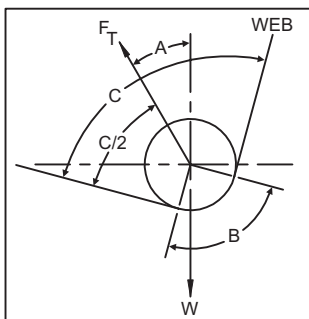

$$\text{NET FORCE} = \frac{4T \sin\left(\frac{B}{2}\right) - W \cos(A)}{2}$$

WRAP 2

Tension Force F_T , **below** horizontal

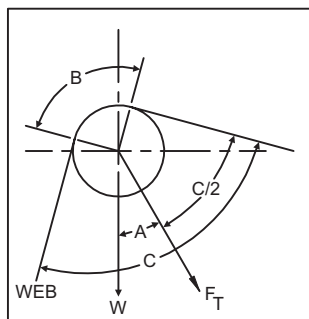

$$\text{NET FORCE} = \frac{4T \sin\left(\frac{B}{2}\right) + W \cos(A)}{2}$$

WRAP 3

Tension Force F_T , **is** horizontal

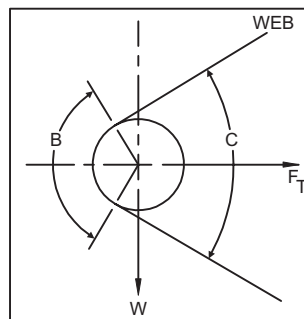

$$\text{NET FORCE} = \frac{4T \sin\left(\frac{B}{2}\right)}{2}$$

W = idler roll weight, T = Maximum web tension, B = Wrap angle = 180° - C°, A = Angle between Tension Force F_T and vertical

TABLE 1

Angle (Degrees)	SINE	COSINE
0	.000	1.000
5	.087	.996
10	.174	.985
15	.259	.966
20	.342	.940
25	.423	.906
30	.500	.866
35	.574	.819
40	.643	.766
45	.707	.707
50	.766	.643
55	.819	.574
60	.866	.500
65	.906	.423
70	.940	.342
75	.966	.259
80	.985	.174
85	.996	.087
90	1.000	.000

DIMENSIONS

SIZE		A	B	C	D	E	F	G	H ₁	H ₂	J	K	L	M	N
1	in.	3.22	0.41	1.80	3/8 - 16	2.19	3.94	0.95	1.75	SEE NOTE 1	3.12	0.53	SEE ROLL WIDTH	0.34	2.50
	mm	82.0	10.4	45.7	M10 x 1.5	55.6	1.00	25	44.5		79.0	13.5		8.6	63.5
2	in.	3.62	0.50	2.60	5/8 - 11	5.12	4.50	1.15	2.36		4.49	0.53		0.53	3.50
	mm	92.1	13.0	66.0	M16 x 2	130.1	114.3	29.2	59.9		114	13.5		13.5	88.9

SIZE		P	Q	R	S	T	U	V	W	X	Y	Z	AA	BB	CC
1	in.	0.87	1.70	0.53	1.30	2.60	2.37	3.88	0.62	5.0	6.0	2.03	3.228 / 3.229	3.00	2.18
	mm	21.9	43.2	13.5	33.0	66.0	60.1	98.4	15.9	127	152.4	51.6	82.00 / 82.02	76.2	55.3
2	in.	0.87	1.70	0.50	1.30	2.60	2.37	3.88	0.62	5.0	6.0	2.18	3.625 / 3.630	3.25	2.50
	mm	21.9	43.2	12.7	33.0	66.0	60.1	98.4	15.9	127	152.4	55.4	92.08 / 92.10	82.6	63.5

MOUNTING STYLE S

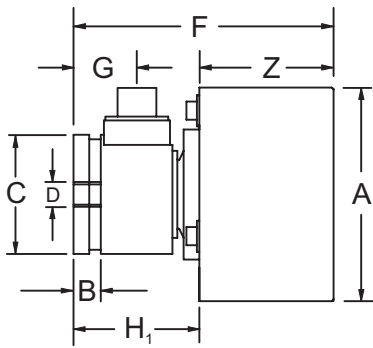

MOUNTING STYLE FL

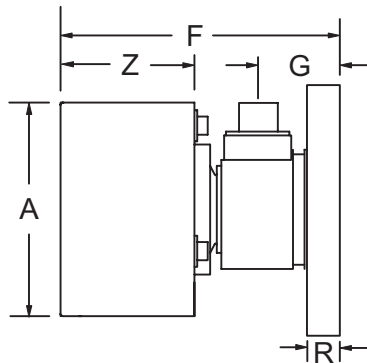

MOUNTING STYLE PB

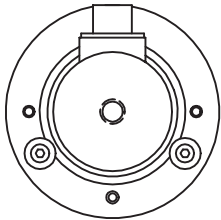
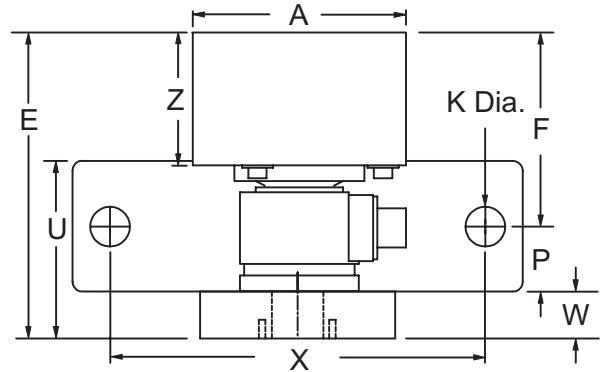

(4) M Dia. equally spaced on N Dia. circle. Flange may be rotated to any position.

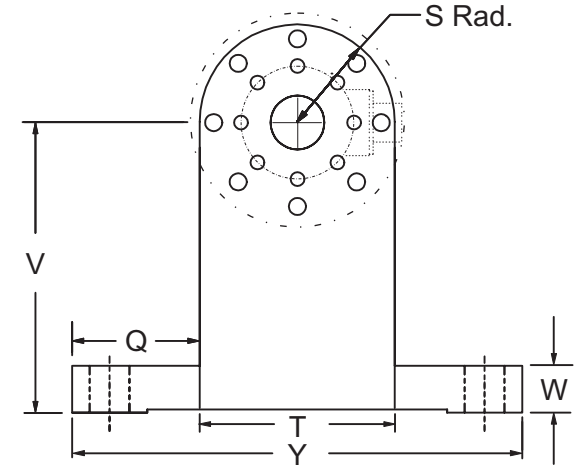
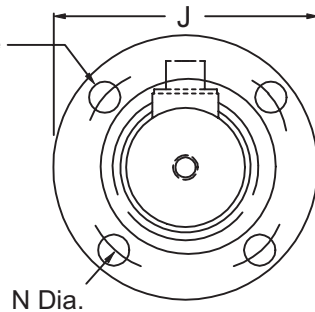

ROLL DIMENSIONS

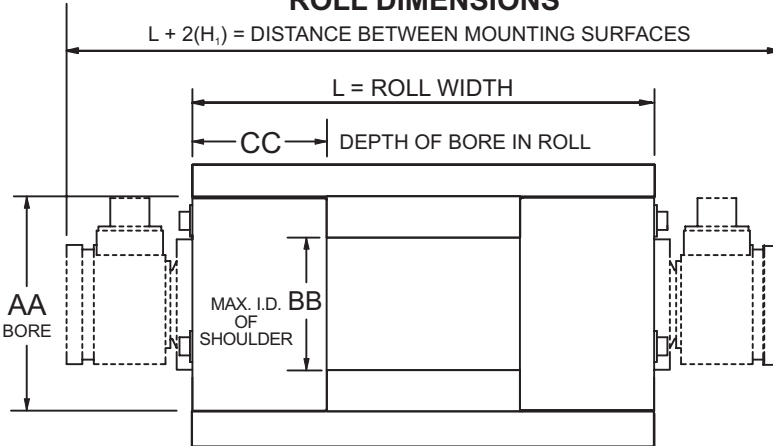

NOTES:

- This product compensates for linear thermal expansion of the roll up to a maximum of 0.25 in. (6.35 mm). Therefore the "H" dimension remains unchanged at the anchored end (H₁) while the floating end (H₂) dimension will change as necessary. Thus, $H_2 = H_1 - [L \times (T_2 - T_1) \times CTE]$ where:
 - T₁ = Temperature of roll when installed
 - T₂ = Temperature of roll when computing H₂ dimension
 - CTE = Coefficient of thermal expansion of roll material
- Labyrinth Seal will reduce thermal expansion capacity from 0.25 inches to 0.21 inches.
- Roll width is specified by customer. Order must say if DFE is to supply roll. See diagram at left for roll measurements.

DFE THE TENSION CONTROL SPECIALISTS
DOVER FLEXO ELECTRONICS, INC.
 217 PICKERING ROAD, ROCHESTER, NH 03867 USA • 603-332-6150 • FAX 603-332-3758
 E-Mail: info@dfec.com • Internet: www.dfec.com • ISO 9001 Certified