

DFE DOVER FLEXP ELECTRONICS, INC.
ISO 9001 CERTIFIED

NARROW WEB TENSION TRANSDUCERS Model NW



5 YEAR WARRANTY

NW NARROW WEB Tension Transducer

The NW Transducer is a specialized bearing-mounted cantilevered idler roll with integrated dual tension sensors for measuring tension in a moving narrow web of paper, film, foil or other material. Constructed of stainless steel and aluminum for excellent corrosion resistance, the NW transducer can be used as the sensing mechanism in a web tension control or display system in a continuous label, tag, or tape process. It mounts on a single-sided machine frame in the path with the cantilevered idler rolls.

Precision sensing elements fixed internally at each end of the idler roll deliver a highly accurate tension signal. The NW measures total web tension regardless of web position on the roll, and regardless of which edge of the web is tighter.

The Narrow Web transducer is available in three roll diameters: NW0 is 2.25 inches (57 mm), NW1 is 3 inches (76 mm), and NW2 is 3.5 inches (89 mm).



BENEFITS

- Measures actual web tension.
- Promotes improved product quality and reduces waste.
- Does not affect the web. No steering effect, web breakage or length change.
- Idler roll is included. Nothing else to buy.
- High accuracy.
- Easy to install.

OPTIONS

- **Extended Range (XR)**. Allows twice the excitation of the transducer being used. Electronics must also have extended range option.
- **Hard Coat (HC)**. Black dye anodized hard coat.
- **Indicator Option (IND)**. Tension display in end of roll with power input (24Vdc) supplied by separate amplifier module (TI26). Connect via cable (std.721-2542 is 5 ft, or specify length on 721-2541). This option is only available on the NW2 size 2 without Extended Range (XR) option. A 25% **Calibration Weight (25CW)**, and **Din Rail Clip (DRC)** mounting option are available for the amplifier.

FEATURES

- Wide operating tension range.
- Two mounting styles: four bolt flange or single bolt.
- Nine roll widths up to 20 inches. Special widths available.
- Used with any standard Dover Tension Controller or Indicator, or with built-in Indicator Display option (Size 2 only).
- Requires little machinery space.

- **Metric Mount Stud (MMS)**. Metric mounting screw for S type transducers.
- **Mounting Spacer (MS)** Spacer to duplicate 2.50" mounting dimension of previous model NWI transducer (size 2 only).
- **Non-Lubricated Bearings (NLB)**. No lubrication for bearings. For lowest drag torque. Voids warranty.
- **Oiled Bearings (OB)**. Uses oil instead of grease for lubrication. For low drag torque. Voids warranty.
- **Steel Roll (SR)**. Roll is made of steel.
- **Stainless Steel Roll (SSR)**. Roll is made of stainless steel.

ORDERING INFORMATION

You may order by description, or by matching the labeled digits with your choices.

Example: NW1-S-10-12-6-XR,OB

NWX - X - X - X - X - OPTIONS
(Separated by commas)

SIZE	MOUNTING STYLE	ROLL WIDTH inch (mm)	LOAD RATING lbs. (N)	CONNECTOR POSITION Viewed from roll end	OPTIONS
0 1 2	S = Screw / Bolt FL = Flange	6 (152) ³ 7 (178) ^{4,8} 8 (203) 10 (254) 12 (305) 14 (356) 16 (406) 18 (457) ⁴ 20 (508) ⁴ Specify ¹	12 (55) 25 (110) 50 (225) 100 (450) 150 (670) ⁹ 200 (400) ¹⁰ 400 (1800) ¹⁰	6 (6:00) Std. 12 (12:00) Rear ⁵	25CM = 25% Calibration Weight ⁶ DRC = Din Rail Clip ⁶ HC = Black dye and anodized hard coat IND = Tension Indicator Display ^{4,8} MMS = Metric Mounting Stud MS = Mounting Spacer ^{4,7} NLB = Non-Lubricated Bearings OB = Oiled Bearings SR = Steel Roll SSR = Stainless Steel Roll XR = Extended Range ² Z = Special (SPR)

Warning!

The NW Size 2 transducer is NOT a direct replacement for the previous NWI transducer.

The electrical connector is different and the end of the roll is closer to the machine frame.

NOTES: 1. Extra cost for non-standard widths. 2. XR option requires electronics to have XRE option; **NOTE:** The XR option is not available with the IND option. 3. Sizes 0, 1 only. 4. Size 2 only. 5. Flange mounting style only. 6. Only used on the IND option for the amplifier/power supply. 7. Cannot be used with rear connector. 8. IND option not available on 7" roll. 9. For Size 0 or 1 with 8" or less roll width. 10. For Size 2 with 8" or less roll width.

SPECIFICATIONS

ELECTRICAL

Excitation: 5 Vdc (10 Vdc with XR option)
Output: 500mVdc, nominal (1 Vdc with XR option)
Gage Resistance: Half bridge at each end of idler roll. 100 Ohms (± 20 ohms), nominal, each gage.
Non-Repeatability: $\pm 1/4\%$ FS, typical
Combined Non-Linearity and Hysteresis: $\pm 1/2\%$ FS
Temperature Range: -10°F to 200°F (-23°C to 93°C), IND Option: 40° to 104°F (4°C to 40°C)
Temperature Coefficient: 0.02% per $^{\circ}\text{F}$, typical (0.036% per $^{\circ}\text{C}$),
Mating Electrical Connector: ITT Cannon KPT06F10-6S
Electrical Connector Position: Connector position is shown by looking at end of roll. Standard is 6 o'clock, same as load direction. Others are 12:00 and Rear (Rear connector position is for Flange mounting style only).

MECHANICAL

Deflection of Sensor Beam: 0.016 inch max (0.41 mm)
Load Ratings: 12, 25, 50, 100, 150, 200, 400 lbs.
 (53, 111, 222, 445, 670, 900, 1800 N)
Overload Rating: Size 0 and 1 = 500 lbs. (2225 N), Size 2 = 1000 lbs. (4449 N) minimum, in load direction, without damage.
Standard Roll Widths: 6, 7, 8, 10, 12, 14, 16, 18, 20 inches (152, 178, 203, 254, 305, 356, 406, 457, 508 mm). 6" available only on Sizes 0 and 1. 7", 18", and 20" available only on Size 2.
Orientation: The transducer may be installed in any position (IND option may be rotated to compensate).
Roll: Material = 6061 Aluminum, Balance = quality grade G2.5 per ISO 1940/1-1986/E & ANSI S2.19-1989, Finish = 32 microinch.
Shaft and Shaft Housing: Stainless steel shaft and aluminum housing.

SELECTION OF LOAD RATING

The Model "NW" Transducer is available with four standard load ratings. The correct transducer load rating for your application is determined by maximum web tension, wrap angle, and roll weight. Choose the appropriate wrap configuration from the diagrams below. Then compute the Net Force using the formula below the diagram. (The direction of the tension force determines which diagram and formula to use). In some cases, the load rating may be less than the computed Net Force. This is acceptable because the Net Force formula contains an oversizing factor of 2, which means that the actual force exerted on the transducer will not exceed its rating.

The following applies only to steel, and stainless steel rolls and rolls in excess of 20 inches (508 mm) in width:

Sometimes a roll is so heavy that its weight uses up most of the operating range of the transducer. When this happens,

it may not be possible to adjust the tension indicating meter to read zero when tension is zero because the adjustment range of the electronic circuit has been exceeded. To find out if the roll is too heavy, compare the load rating with the effective weight of the roll as follows: The effective roll weight is the "W COS(A)" term in the formula. If W COS(A) is more than 95% of the load rating chosen, the tension meter will probably not be adjustable to zero. If this is the case, one or more of the following changes must be made to reduce W COS(A) to less than 95% of the load rating:

1. Reduce the transducer roll weight
2. Increase angle (A)
3. Use the next higher load rating (this is the least desirable choice because it reduces transducer signal output).

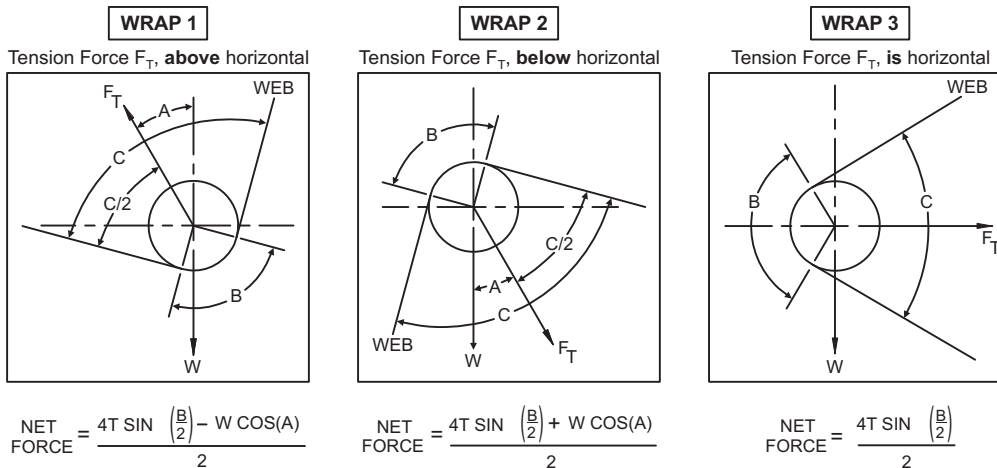

TABLE 1		
ANGLE	SINE	COSINE
0°	0.000	1.000
5°	0.087	0.996
10°	0.174	0.985
15°	0.259	0.966
20°	0.342	0.940
25°	0.423	0.906
30°	0.500	0.866
35°	0.574	0.819
40°	0.643	0.766
45°	0.707	0.707
50°	0.766	0.643
55°	0.819	0.574
60°	0.866	0.500
65°	0.906	0.423
70°	0.940	0.342
75°	0.966	0.259
80°	0.985	0.174
85°	0.996	0.087
90°	1.000	0.000

W = idler roll weight (See Note 1), T = Maximum web tension, B = Wrap angle = $180^{\circ} - C^{\circ}$, A = Angle between Tension Force F_T and vertical

Note 1: Roll weight equals weight of roll shell plus weight of bearing assemblies. Use chart below

Roll Weights (Aluminum)	6"	7"	8"	10"	12"	14"	16"	18"	20"	Bearing Assembly
NW0	lbs	0.84	1.15	1.45	1.76	2.06	2.37	0.25
	kg	0.38	0.52	0.66	0.80	0.94	1.08	
NW1	lbs	1.63	2.23	2.83	3.43	4.03	4.64	1.0
	kg	0.74	1.01	1.28	1.56	1.83	2.10	
NW2	lbs	1.3	1.6	2.2	2.6	3.1	3.5	4.0	1.7
	kg	0.59	0.73	1.0	1.18	1.41	1.59	1.82	

DIMENSIONS
inches (mm)

		A	B	C	D	E	F	G	J	K	L	N
NW0	IN	6-16	2.25	1.56	1.80	1.67	0.24	3.12	2.50	1/2-13	0.38	0.34
	MM	152/406	57.2	39.6	45.7	42.4	6.1	79.2	63.5	M12	9.7	8.64
NW1	IN	6-16	3.00	1.56	2.60	2.40	0.28	4.49	3.50	1/2-13	0.38	0.53
	MM	152/406	76.2	39.6	66.0	61.0	7.1	114	88.9	M12	9.7	13.5
NW2	IN	7-20	3.50	1.56	2.60	2.40	0.28	4.49	3.50	5/8-11	0.38	0.53
	MM	178/508	88.4	39.6	66	62.0	7.1	114	88.9	M16	9.7	13.5

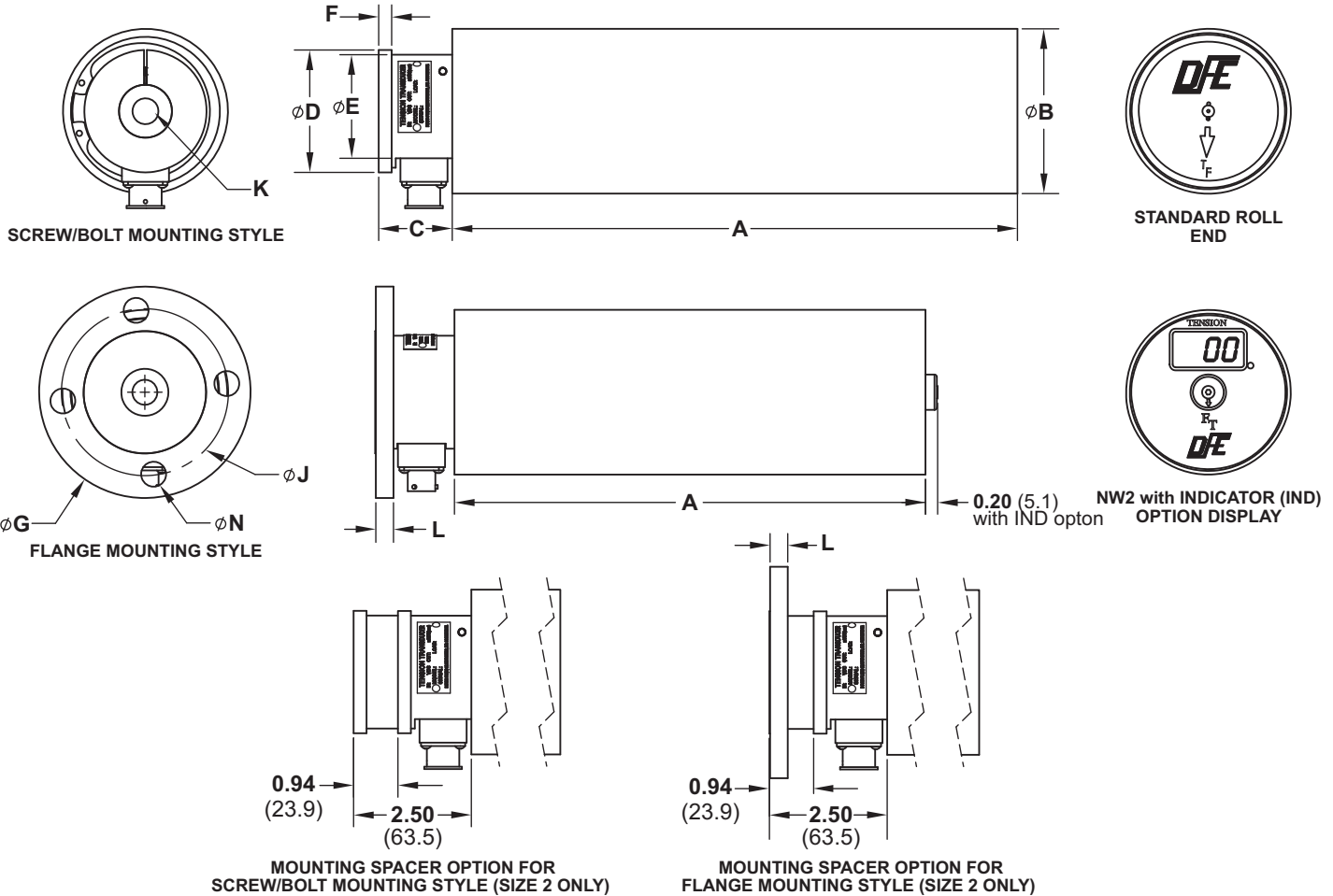

DIMENSIONS FOR AMPLIFIER MODULE FOR IND OPTION

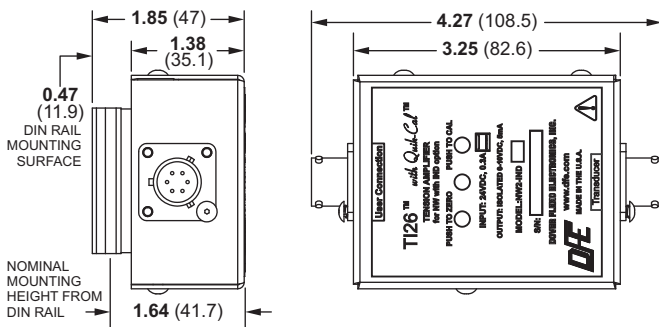

NW2 shown with IND option, amplifier module, optional 12 o'clock connector position, and five foot long 721-2542 cable.

DFE THE TENSION CONTROL SPECIALISTS
DOVER FLEXO ELECTRONICS, INC.
 217 PICKERING ROAD, ROCHESTER, NH 03867 USA • 603-332-6150 • FAX 603-332-3758
 E-Mail: info@dfec.com • Internet: www.dfec.com • ISO 9001 Certified